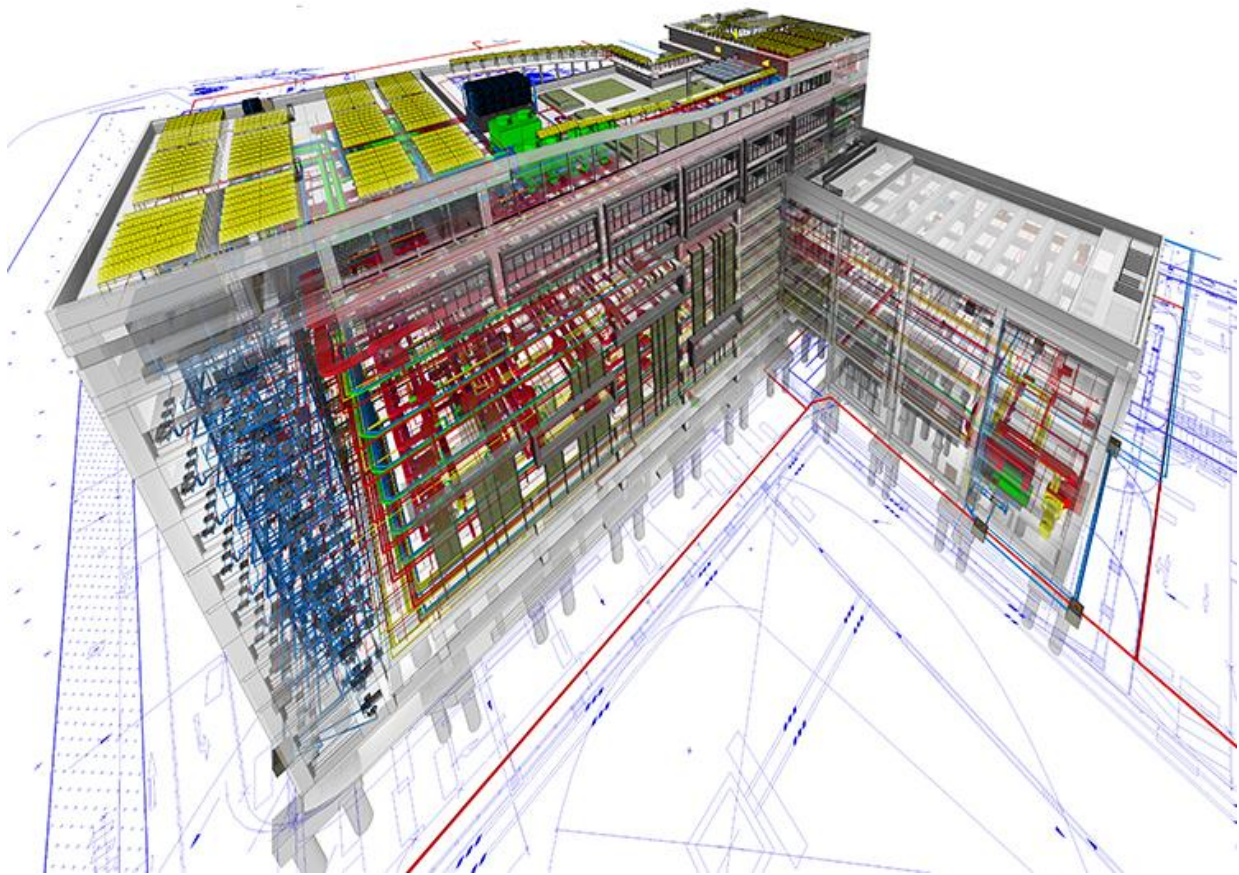


# BIM Essential Guide

## For Contractors



BCA acknowledges the leadership provided by the BIM Steering Committee in support of the production of the BIM Essential Guides

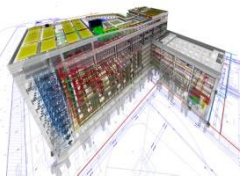
The BIM Essential Guides have been drafted by the Centre for Construction IT on behalf of BCA and the BIM Steering Committee.

©Building and Construction Authority 2013

Building and Construction Authority  
5 Maxwell Road  
#16-00 Tower Block MND Complex  
Singapore 059110  
[www.bca.gov.sg](http://www.bca.gov.sg)

First published August 2013

While every effort has been made to ensure the accuracy and quality of information contained in this publication, the Building and Construction Authority, its employees, agents or industry partners can take no responsibility for the subsequent use of this information, nor for any errors or omissions that it may contain.



Cover image and design courtesy of RSP Architects Planners & Engineers (Pte) Ltd and the BCA Academy of the Built Environment.

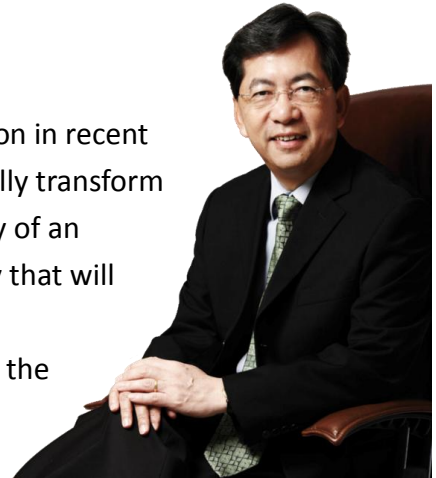
## Contents

CEO's Message	iv
ACKNOWLEDGEMENTS	v
OBJECTIVES	1
Suggested BIM uses	2
Tender Stage	3
Developing BIM Model(s)	4
Cost Estimation	5
Site Planning (Logistic Planning)	7
Pre-Construction Stage	11
Reviewing Consultant Models	12
Model-based Project Planning and Scheduling	15
Construction Stage	16
Construction Coordination	17
Preparing and Reviewing of Shop Drawings	20
Sequencing Complex Construction	23
Setting out and Verification on Site	27
Prefabrication	29
Preparation of As-built Model	34
Preparation of BIM Model for Operation and Maintenance	35
Appendix A – Suggested Colour Coding for Modelling	37
ACMV	37
Electrical	38
Protection, Plumbing, Sanitary & Gas	39

## CEO's Message

Dear readers,

Building Information Modelling (BIM) has gained much traction in recent years as digital construction technology that will fundamentally transform the building and construction industry practice in the delivery of an excellent built environment. It is a game changing technology that will improve the construction productivity as well as the level of integration and collaboration across the various disciplines in the construction value chain. It is therefore important for the industry to embrace the technology with clarity.



The BIM Essential Guides are part of the industry's efforts to demystify BIM and to give clarity on the requirement of BIM usage at different stages of a project.

Under the leadership of the BIM Steering Committee chaired by Er Lee Chuan Seng, Emeritus Chairman, Beca Carter, and comprising of leaders in BIM, the BIM Managers Forum has contributed much time and effort to compile the various best practices to make this Guide possible over a short span of time. We would like to thank them for their contribution.

We hope that every BIM user can truly reap the benefits of BIM by integrating it into his/her day-to-day workflow – from feasibility study to facility management. We hope that BIM users can use these guides as a platform to jumpstart their BIM adoption, before they leap to greater heights, innovating and transforming their workflow.

BIM is a journey. We envisage that it will grow with time and will inspire more advanced and innovative use of BIM. I would like to encourage all BIM practitioners to join in this industry effort to grow this Guide into a wealth of BIM knowledge.

Dr John Keung

## ACKNOWLEDGEMENTS

BCA would like to acknowledge the contributions of the following organizations which had provided their valuable inputs in the development of this guide:

BYME Singapore Pte. Ltd.

Dragages Singapore Pte. Ltd.

Hexacon Construction Pte. Ltd.

Lian Soon Construction Pte. Ltd.

M+W Singapore Pte. Ltd.

Obayashi Singapore Pte. Ltd.

Sato Kogyo Singapore Pte. Ltd.

Shimizu Corporation

Singapore Piling & Civil Engineering Pte. Ltd.

Tiong Seng Contractors Pte. Ltd.

Woh Hup Pte. Ltd.

Centre for Construction IT, BCA

Sophie Montenot

Marcel Finlay

Hugues Desclaux

Yap Hong Keng

Louis Tay

Tian Ai Ling

Ng Siew Loong

Soe Min Tun

KY Fong

Joseph Sim

Simon Lum

Nilar Win

Edmund Leong

Ang Kooi Fung

Phan Manh Quyet

Chidambaram

Jusuf Anggono

Angela Lee

## OBJECTIVES

The objective of this Essential Guide is to help contractors to understand the benefit of various BIM uses during various stages. A more graphical approach is chosen to easily show the possible use-cases of BIM in different stages such as the Tender stage, Pre-Construction stage, and Construction stage.

While we try to cover several BIM uses scenarios for a typical BIM project, it is not an extensive document that covers all scenarios that might arise for a specific project.

The chapters are not organised in any particular sequence. Implementing any BIM use for different stages will depend on several factors such as the client requirements, the availability of technical expertise in the firm, project timeline, and the project delivery method (e.g. traditional method or Design and Build method).

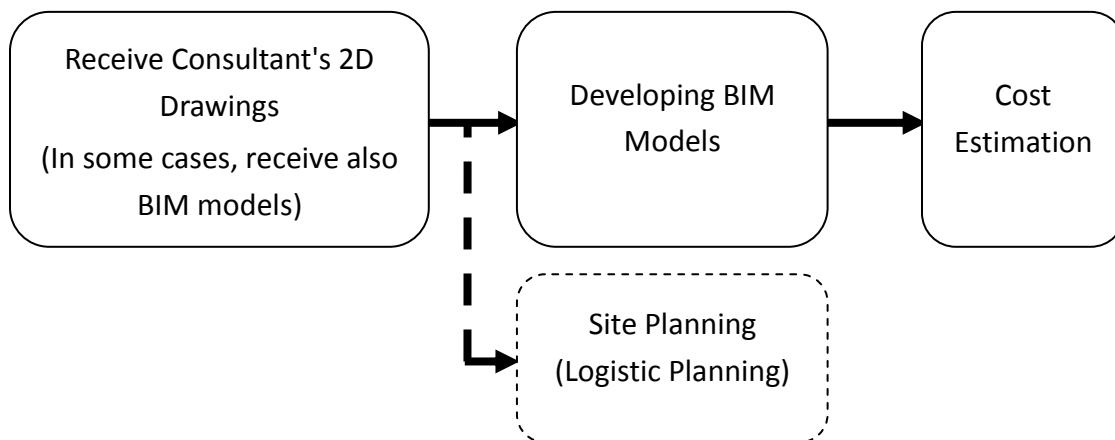
---

## Suggested BIM uses

STAGE	SUGGESTED BIM USES (CONTRACTOR ONLY)
<b>1. Tender</b>	a. Developing BIM Model(s) b. Cost Estimation c. Site Planning (Logistic Planning)
<b>2. Pre-Construction</b>	a. Reviewing Consultant Models b. Model-based Project Planning and Scheduling
<b>3. Construction</b>	a. Construction Coordination b. Shop Drawings and Model c. Sequencing Complex Construction d. Setting Out and Verification on Site e. Prefabrication f. As-Built models g. Model for Facility Management

## Tender Stage

A typical tender stage workflow is as follows:



The primary use of the contractors' BIM models at tender stage is for cost estimation.

In current practice, a contractor may receive BIM models (in DWF/3D PDF/IFC/Native format) in addition to 2D tender drawings at the tender stage. The BIM models are for reference while the 2D drawings are the contractual documents.

The contractors may choose to develop their own BIM models based on the consultants' 2D drawings while using the consultants' BIM models as references. The contractor may choose to use the consultants' BIM models.

Some contractors may also choose to use BIM model for site planning at the tender stage to better appreciate the site constraints and for logistic planning.



## DEVELOPING BIM MODEL(S)

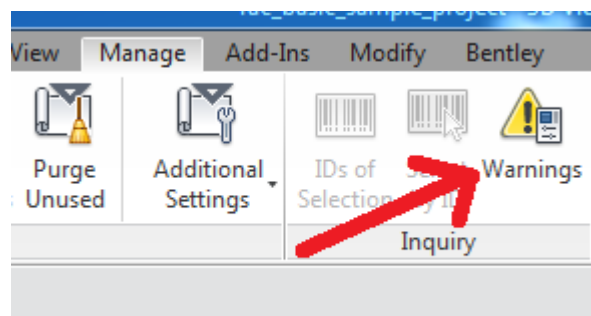
When developing BIM model, the contractor could follow the following good practices

- Keep model as light as possible.
- Model only essential details that help the contractor in his tasks such as for constructability study or visualisation.
- Add additional information to the model needed by downstream models users.

Revit users could learn some modelling tips from the **“Best Practices in Revit”** page at BIM@SG website<sup>1</sup>. In this page, Revit users could learn the following:

- What needs to be done before the project begins,
- How to start a project,
- How to model efficiently, and
- File maintenance.

Should the contractor decided to use the consultants’ BIM models for his tasks (e.g. cost estimation), he should reviewed the quality of the models. Readers could refer to **Singapore BIM Guide Quality Assurance section** for more information on types of quality checking. Revit users could check the models by reviewing the warnings function as shown

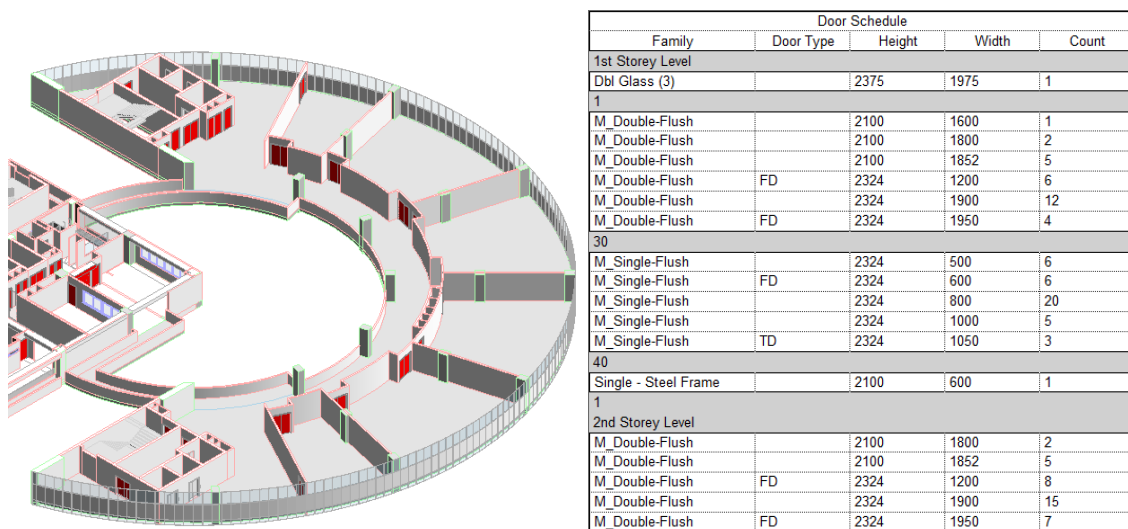


*Figure 1 Using Warnings in Revit to check model quality*

<sup>1</sup> <http://bimsg.wordpress.com/best-practices/autodesk-revit/>

## COST ESTIMATION

Quantity takeoffs are usually used as a basis for cost estimations during the tender stage. After the contractors develop the BIM models (or receive the consultants' BIM models), the BIM software could be able to generate the lists of objects that can be linked to an external cost database to get a cost estimation.



*Figure 2 List of object generated from the BIM model*

When doing the quantity takeoffs, it is necessary to be consistent in measuring the quantities. For example, the length of a wall might be measured from the centreline or the outside which will give a different calculated area. The method in modelling the building components (e.g. piles and pile cap) also plays a key role in extracting the right quantity.

The BIM model could also be exported to other BIM software application for estimation. Such software usually comes with measurement tools, cost library, and reporting tools.

Although BIM software is able to perform the quantity takeoff and cost estimation effectively, one should always verify the BIM results against other means.

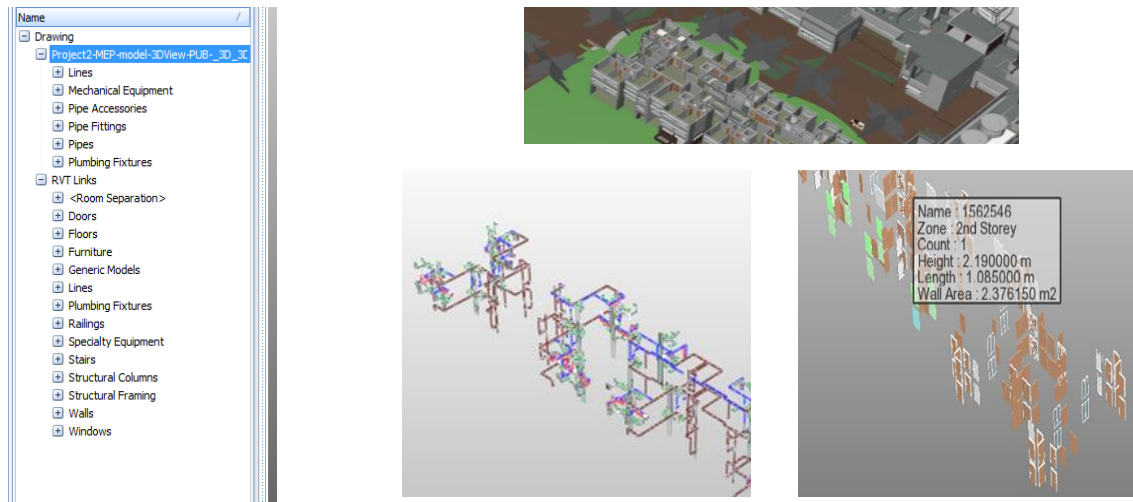


Figure 3 BIM QS application can read BIM model (Image courtesy of HDB and KPK)

	A:Code	B:Description	C:Quantity	D:Unit	E:Rate	F:Subtotal	G:Factor	H:Total
1		HDB_A_Door_Alum Bi-fold Door 1020 x 2190 mm (SY)	14	no	0.00	0		0
2		HDB_A_Door_Alum Bi-fold Door 1085 x 2190 mm (WC)	40	no	0.00	0		0
3		HDB_A_Door_Alum Door Double Panel_BR 1500 x 2190 mm (DT/2E)	3	no	0.00	0		0

Below the table is a software interface with navigation buttons and a 'Cost Calc' button.

Figure 4 BIM QS application cost estimation workbook (Image courtesy of CostX)

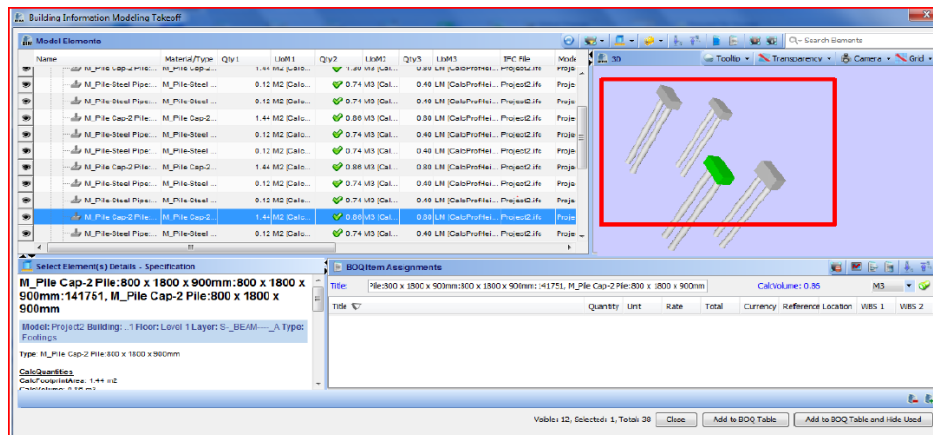


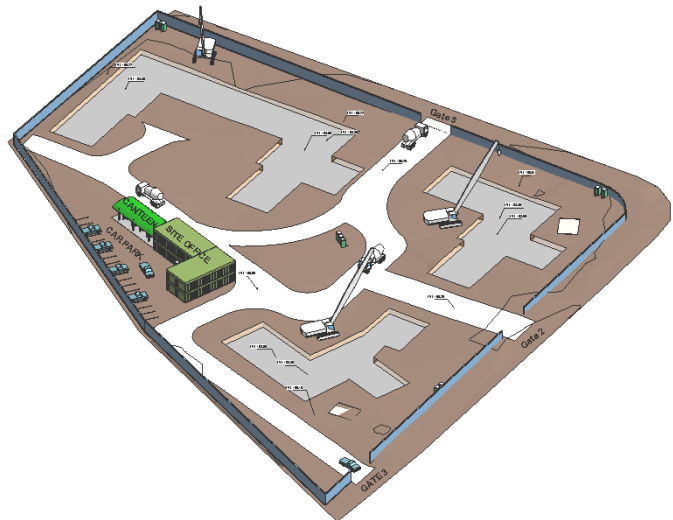
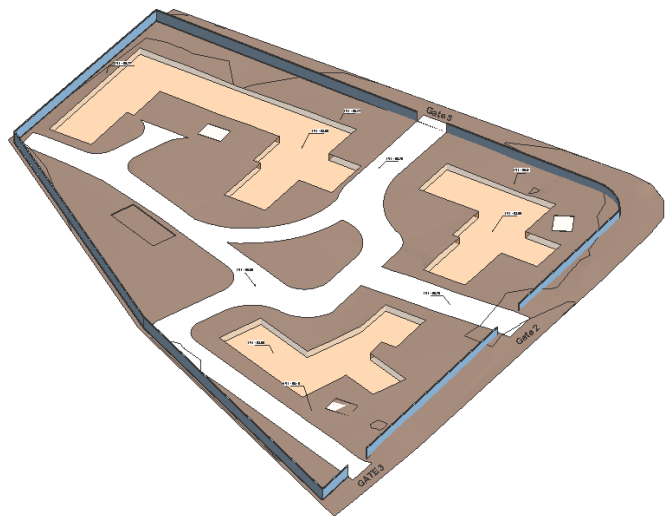
Figure 5 Piles and pile cap are modelled as separate elements so that formwork for pile cap can be determined in BIM QS tool (Image Courtesy of Lian Soon Construction Pte. Ltd. and CostOS)

## SITE PLANNING (LOGISTIC PLANNING)

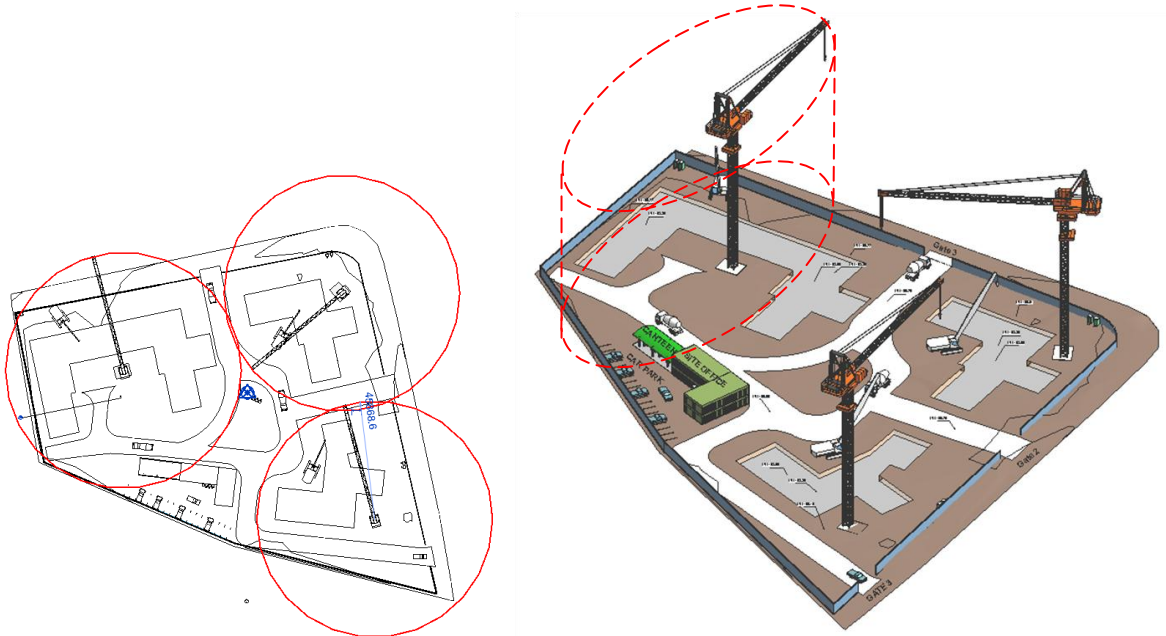
Contractor could use BIM-based site planning to understand job site constraints and a visual aid to communicate with the client. At the latter stage, BIM-based site planning could also be extended for identifying hazards and communicating safety management plan to the workers.

The following steps are usually involved in site planning:

- Model the site topography
- Add hoardings along the boundary with site access (gates)
- Plan and model internal roads and pedestrian access inside the site, temporary work
- Model the site offices, storage areas and utilities
- Plan the vehicle movements and mobile crane movements. The movements could also be animated to identify possible risks and eliminate unexpected situations



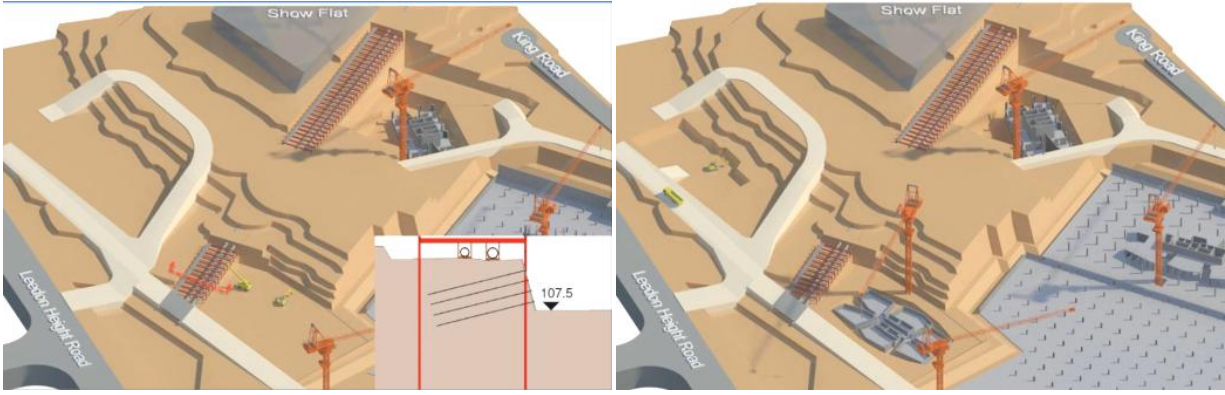
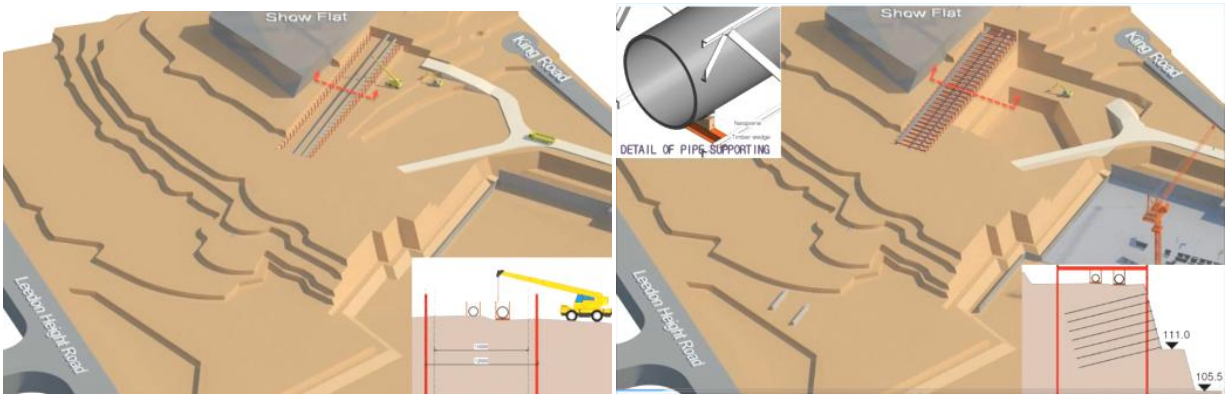
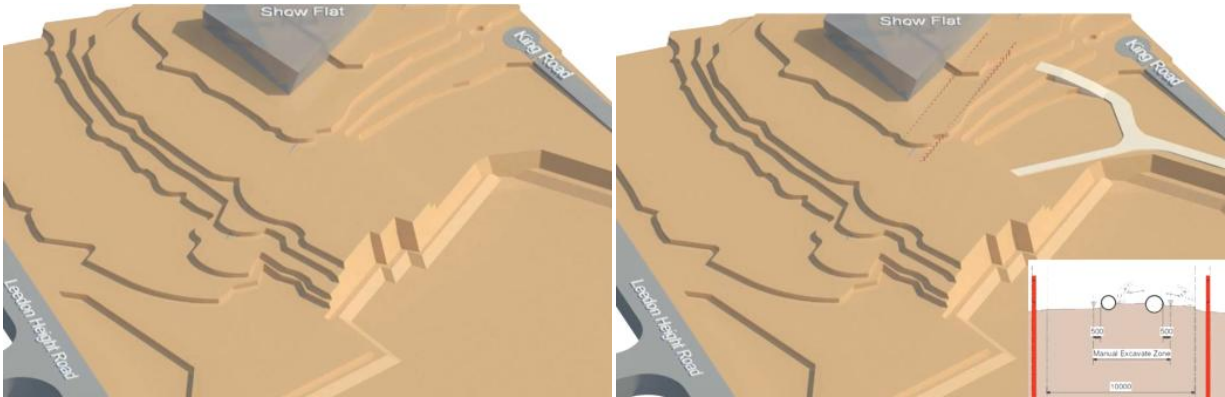
- Plan locations of Tower Cranes and model them to identify swing circumferences of the cranes to ensure that safety distances between cranks and nearby temporary and permanent structures are maintained. Positioning of the Tower Cranes should also take the architectural massing models (if provided) into consideration.

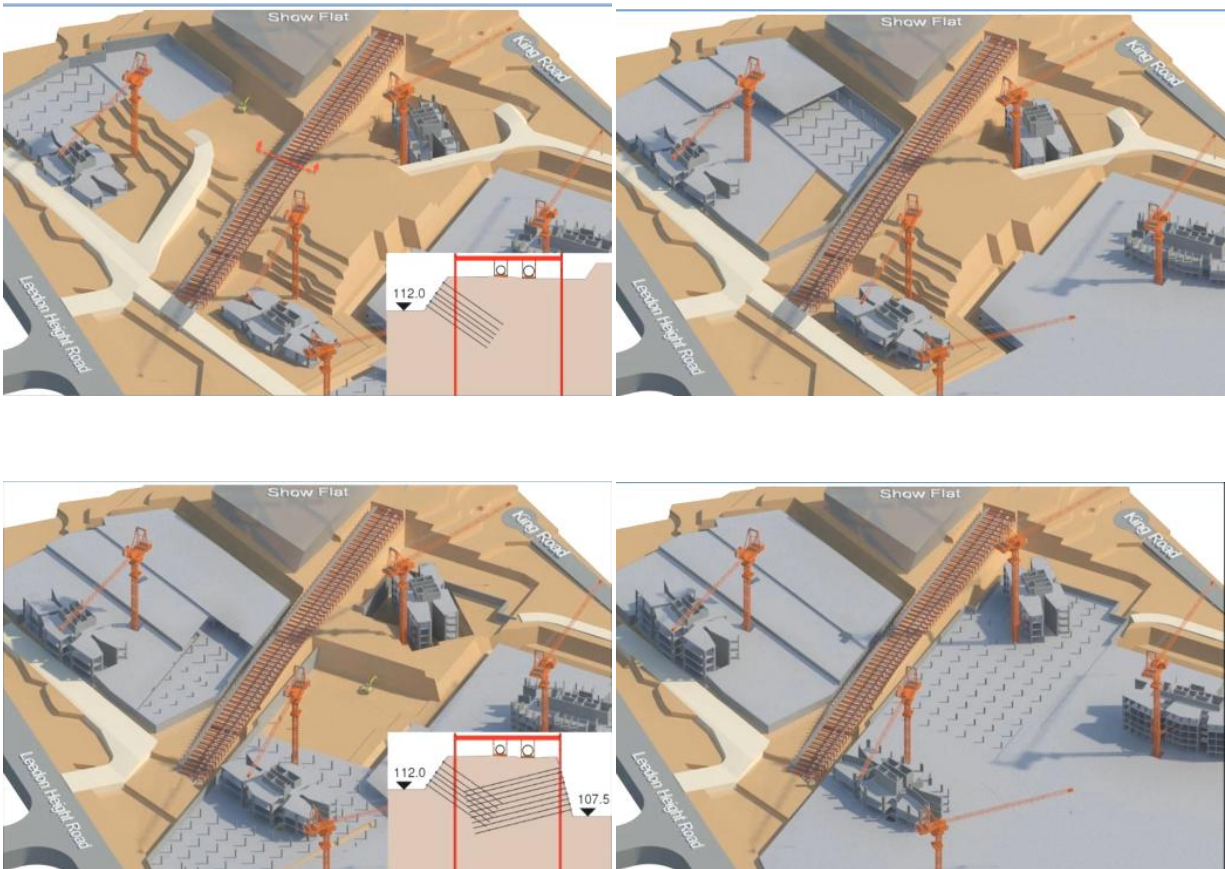


Once the site plan model is developed, the main contractor could communicate the site plan to his sub-contractors and workers using:

- The 3D walk-through or renderings
- The 4D simulations or animation videos

Using either of the above communication modes, sub-contractors or workers on site will have a better understanding of the schedule, what to avoid (e.g. existing PUB services) or which zone to work on when.

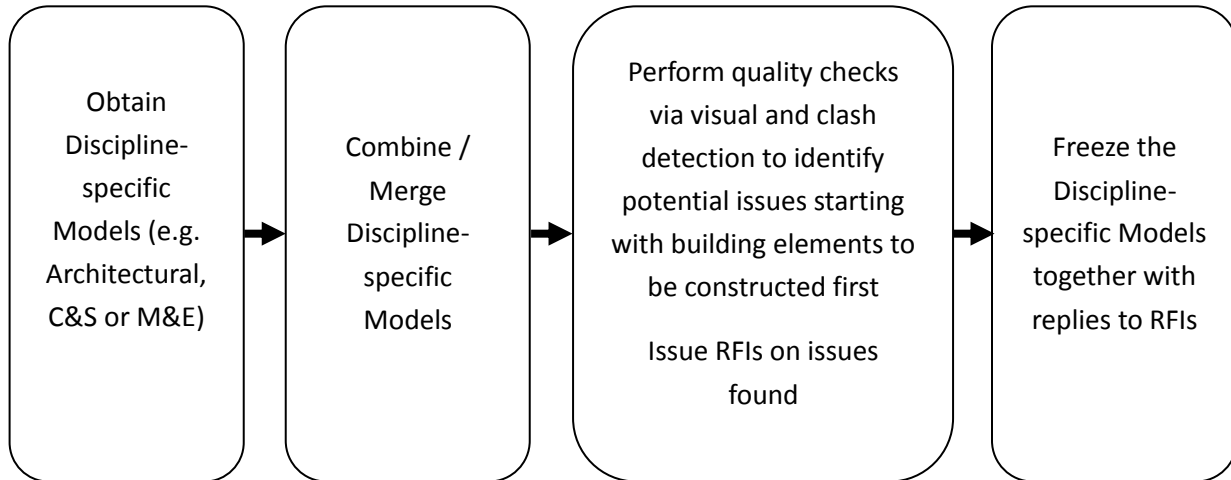




*Figure 6 Site plan sequencing was used to communicate to the site workers on the working zones to avoid schedule clash (Image courtesy of Woh Hup Pte. Ltd.)*

## Pre-Construction Stage

A typical pre-construction workflow is as follows,





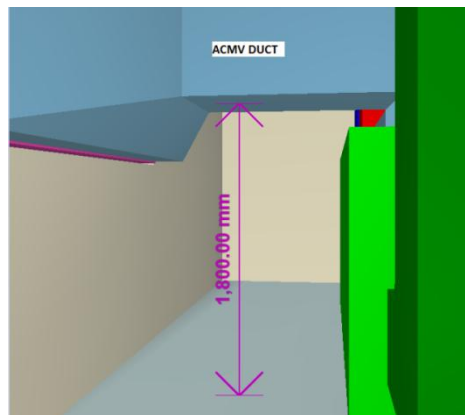
## REVIEWING CONSULTANT MODELS

Upon receipt of the consultant models, contractors could start to review the models before using them for say coordination purpose.

In the Pre-Construction stage, contractor could review the Architectural, Structural and MEP models starting from the building elements to be constructed first.

The following items are commonly checked by the contractors during the pre-construction stage:

- All discipline-specific models have the same levels
- All M&E penetration areas that might affect the structural and architectural model
- How building elements are modelled (e.g. whether a wall is modelled as one-piece or broken up by level)
- Compliance with building regulations

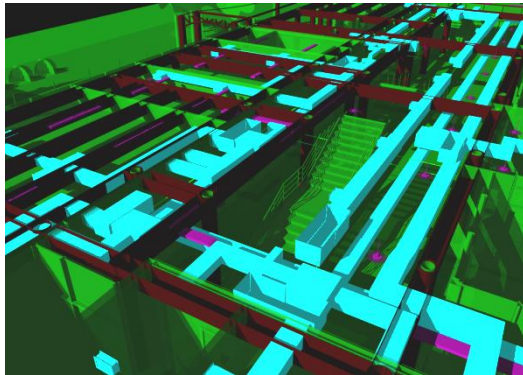


*Figure 7 Low head room below the duct*

The following steps could be used when reviewing the discipline models:

**Step 1:** Import Architectural, Civil and Structural, and MEP models into project coordination/project review software. **Make sure the models are located in a common coordinate system.**

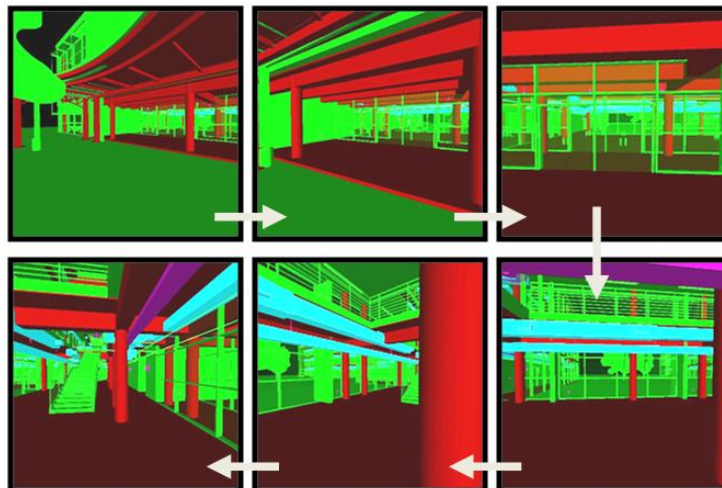
**Step 2:** Assign/change colours for each discipline model. This helps to identify source (discipline) of the element when an issue is encountered. Suggested colours by discipline are shown below. Project members should agree on the colouring convention for the project. *Avoid colours that used for error/highlight by the Project Review Tool.*



Architecture:	Dark Green + 30% Transparency
Structure:	Dark Brown
ACMV:	Light Blue
Plumbing:	Light Green
Sewer:	Yellow
Fire Protection:	Light Red
Electrical:	Purple

*Figure 8 Assign colour for each discipline models to ease viewing*

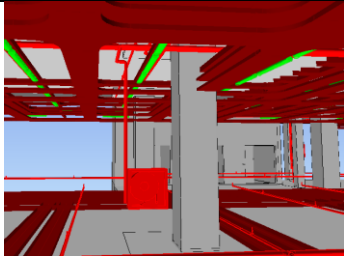
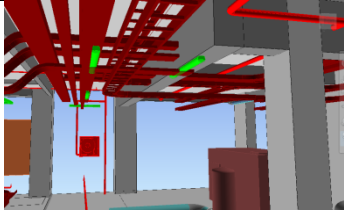
**Step 3:** Visual check using the navigation tools of the project review software (Zoom, Pan, Orbit, Walkthrough and Section). Refer to *Singapore BIM Guide: Appendix B (ii) Quality Assurance* for list of elements that need to be co-ordinated.







*Figure 9 Using walkthrough to do visual checking*

**Step 4:** Use automatic clash checking tools of the project review software to check for clashes. Save the clashes views, add comments, and export and attached them as part of the RFI documents. Alternatively, generate a coordination report from the project review software for follow up.

**Step 5:** Prioritise the issues and resolve them one by one with the relevant parties involved.

No.	Model Review Comment	Model Screen Shot	Action by		Resolved
					Y / N
1	Cable support clashes with structure column				
2	Lighting clashes with cable support				

*Figure 10 Combined Service Model Coordination Report (Image Courtesy of M+W Singapore Pte. Ltd.)*

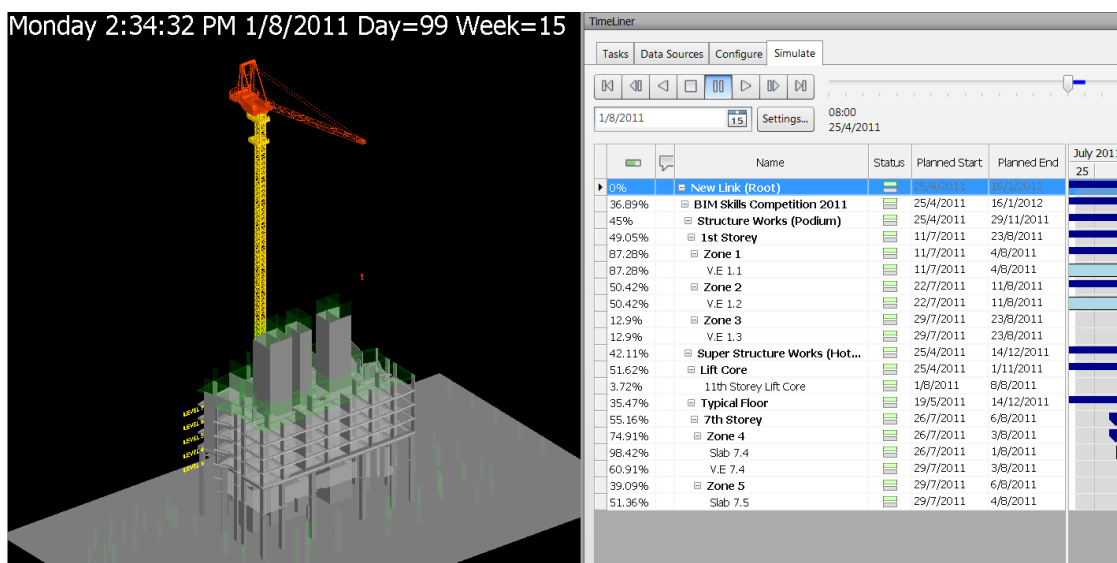
Image	Clash Name	Status	Distance	Description	Date Found	Assigned To	Clash Point	Item 1				Item 2			
								Item ID	Layer	Item Name	Item Type	Item ID	Layer	Item Name	Item Type
	New Clash Group	New	-0.30	Hard	2012/6/11 04:20.38		x:-28.86, y:-34.11, z:3.20	Element ID: 720998	B4	Internal_RC_300mm	Solid	Element ID: 503280	<No level>	Radius Elbows / Tees	Solid
	Clash5	New	-0.03	Hard	2012/6/11 04:20.38	Archi Team	x:108.36, y:-32.74, z:3.30	Element ID: 721010	B4	Internal_RC_300mm	Solid	Element ID: 645265	Level 1	300 x 200	Composite Part
	Clash6	New	-0.03	Hard	2012/6/11 04:20.38		x:-26.66, y:-31.93, z:2.51	Element ID: 721018	B4	Internal_BK_200mm	Solid	Element ID: 533312	<No level>	Radius Elbows / Tees	Solid
	Clash7	New	-0.03	Hard	2012/6/11 04:20.38		x:-26.86, y:-31.73, z:2.50	Element ID: 721018	B4	Internal_BK_200mm	Solid	Element ID: 518138	<No level>	Radius Elbows / Tees	Solid

*Figure 11 Example of automatic generation of coordination report*

## MODEL-BASED PROJECT PLANNING AND SCHEDULING

One can perform model-based project planning and scheduling to demonstrate how the construction is to be executed from start to the end of the project. Contractors could also use model-based project planning and scheduling for other purposes:

- Marketing purposes, publicity, or even public hearing
- Communicating to owner and/or other project participants (e.g. sub-contractors) on the phasing schedule and showing critical path of the project
- Identifying space and workspace conflicts
- Evaluating various alternate resources and scope of works over a period of time to optimise the resources and labour usage accordingly

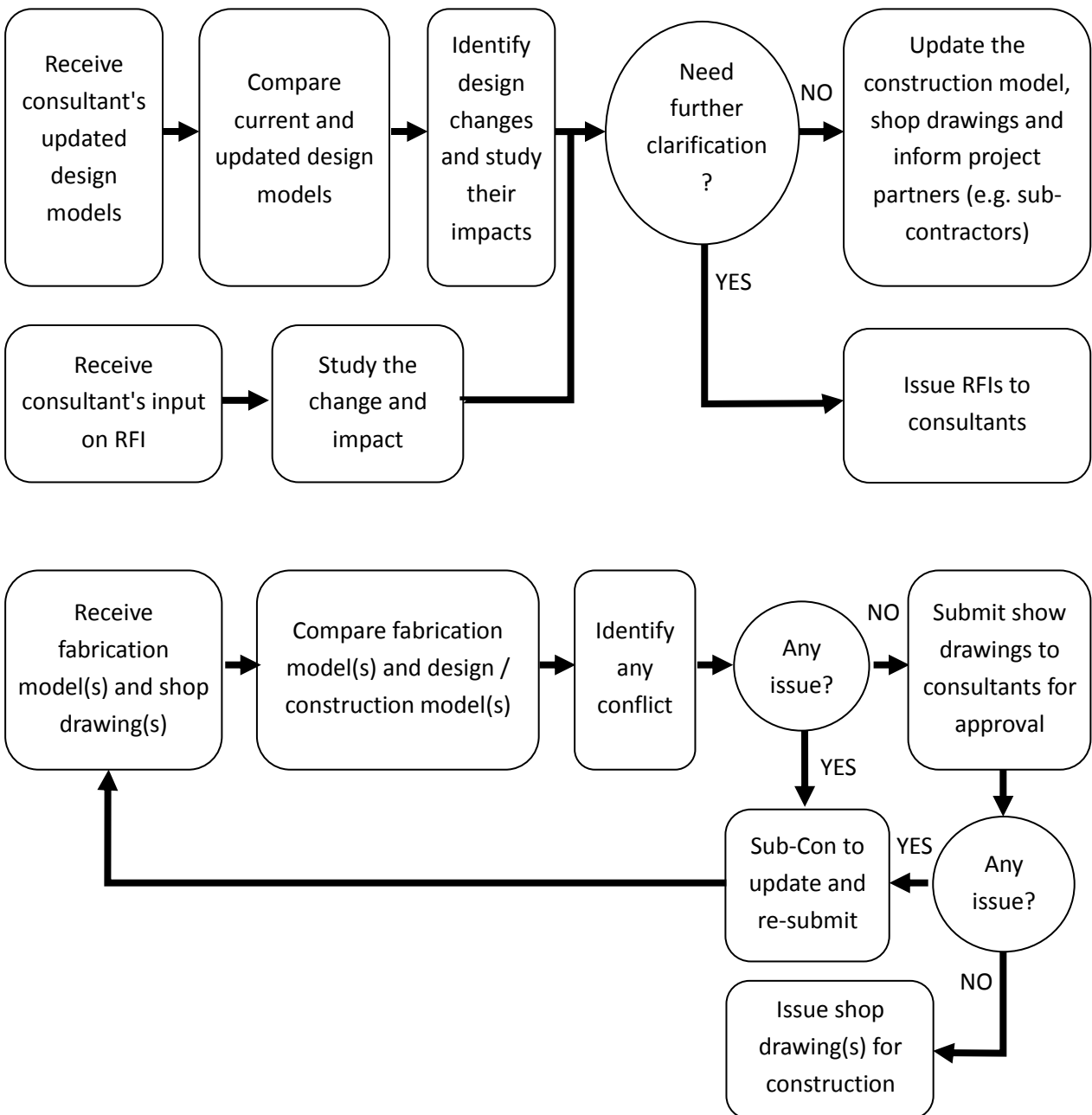


*Figure 12 Sequencing of the structural elements as per casting cycle (Image courtesy of Woh Hup Pte Ltd)*

One could start with macro level scheduling for communication purposes. For micro scheduling, one would require a more detailed model with elements link to project schedule.

## Construction Stage

A typical workflow at the construction stage is shown below. It is likely to involve working with the consultants' and sub-contractors' models.



## CONSTRUCTION COORDINATION

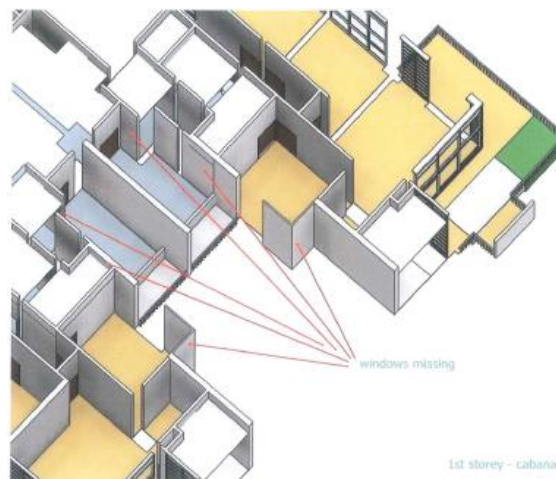
At Construction stage, contractors could coordinate architectural, structural and MEP models in pairs. Similar steps outlined in Reviewing Consultant Model (at the Pre-Construction stage) section could be repeated.

Some good practices in managing clashes are as followed:

- Use clash rules to reduce false positives<sup>2</sup>
- Develop process in managing multiple clash test<sup>3</sup>
- Group similar issues together that affect specific trades or specific types of issues; Filter out issues that are not relevant (or can be resolved on site); and Sort the result to quickly narrow down the most serious issues<sup>4</sup>

The following examples are common RFIs raised by the contractors during the construction stage:

1. Missing elements/information.



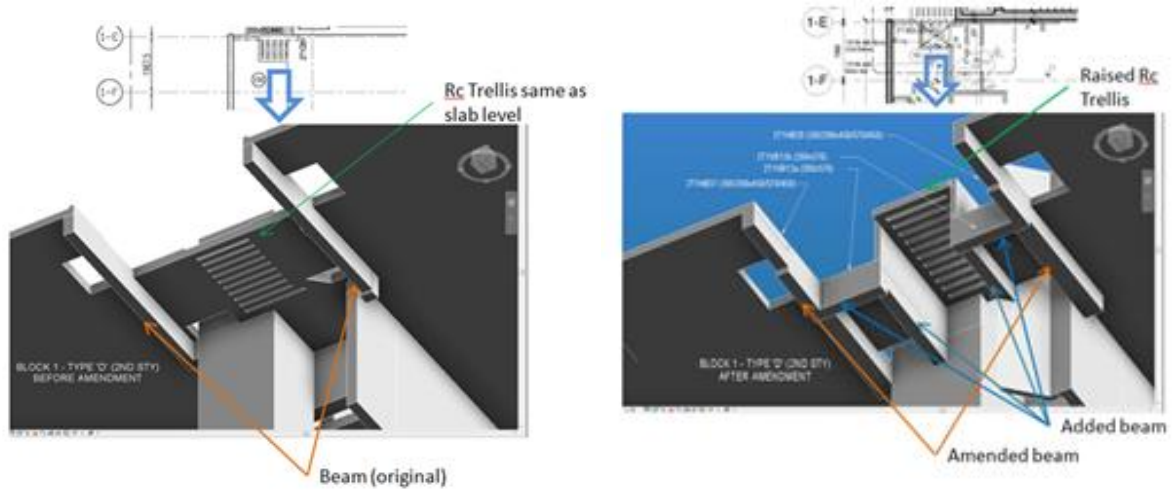
*Figure 13 Windows are missing from the model (Image courtesy of ARC Studio)*

<sup>2</sup> <http://beyonddesign.typepad.com/posts/2012/08/using-clash-rules-in-navisworks-to-reduce-false-positives.html>

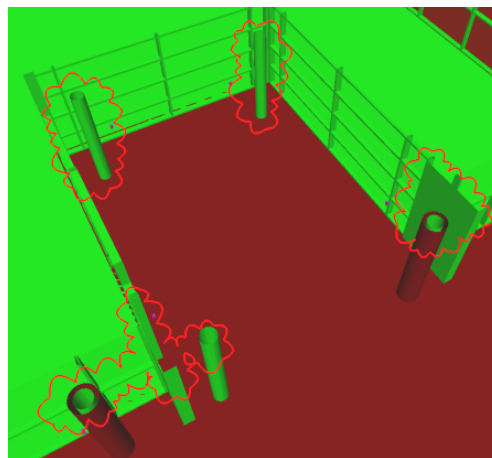
<sup>3</sup> <http://beyonddesign.typepad.com/posts/2012/09/managing-multiple-clash-tests.html>

<sup>4</sup> <http://beyonddesign.typepad.com/posts/2012/09/grouping-filtering-and-sorting-clash-results-in-navisworks.html>

## 2. Highlighting design discrepancies

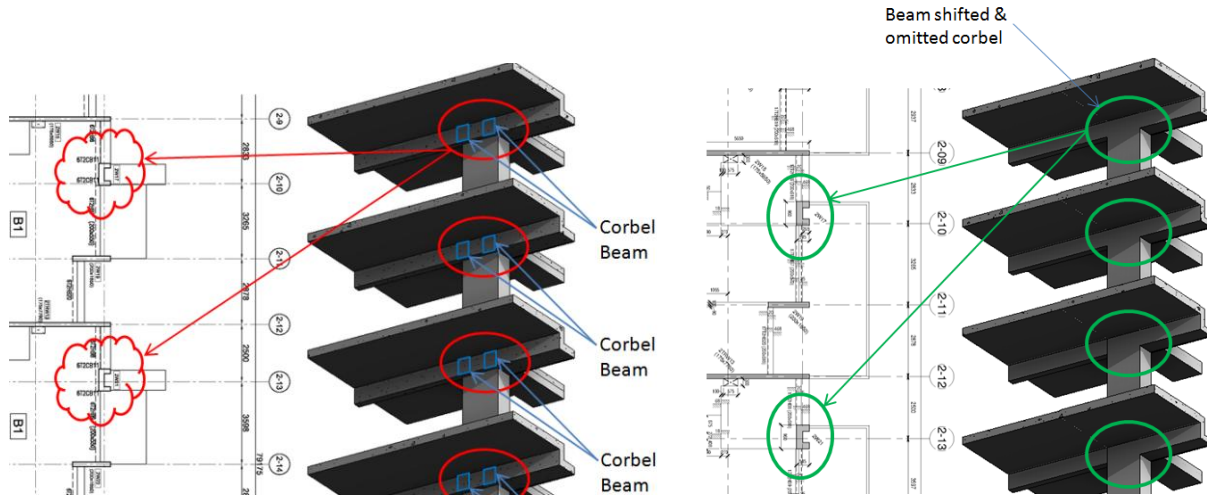


*Figure 14 Consultant's model, before and after amendment by contractor (Image courtesy of Woh Hup Pte. Ltd)*



*Figure 15 Missing structural columns; architectural columns are smaller than structural columns*

### 3. Constructability issues.

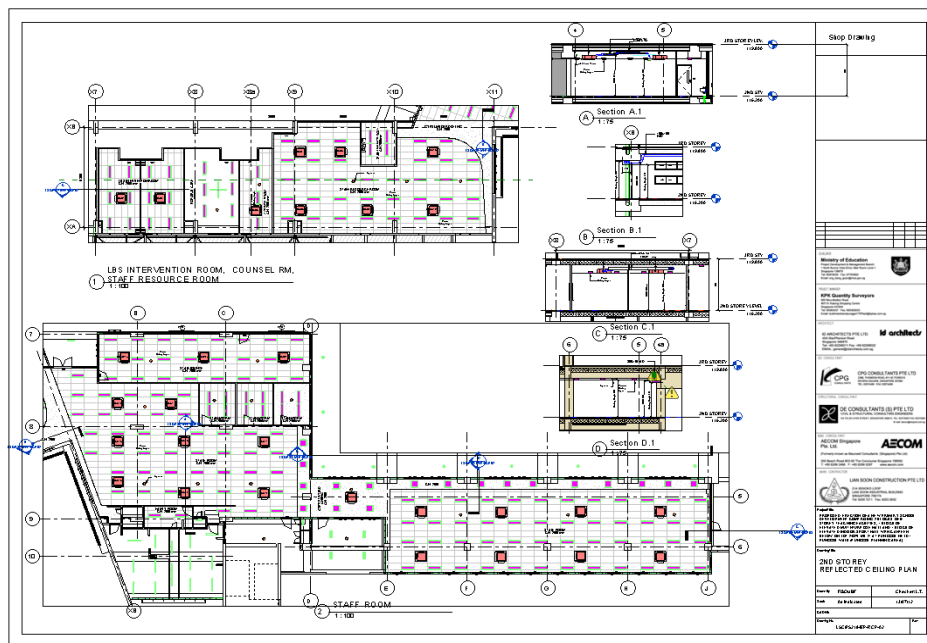


*Figure 16 Contractor proposed design alternatives to ease the construction process (Image courtesy of Woh Hup Pte. Ltd)*



## PREPARING AND REVIEWING OF SHOP DRAWINGS

Contractor could generate the construction shop drawings (such as Combined Services Drawings) directly from the construction model to get a well coordinated and consistent documentation.

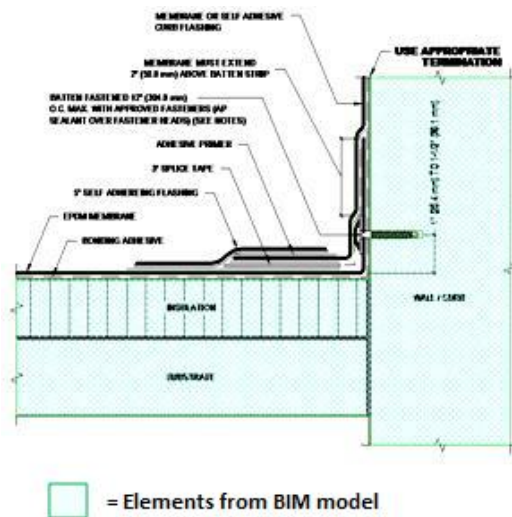


*Figure 17 Combined Services Drawings (Image courtesy of Lian Soon Construction Pte. Ltd.)*

For a more detail drawings (e.g. fabrication shop drawings), contractor could adopt a hybrid approach that create drafting views from BIM models and add 2D line works.

For the hybrid approach, the following steps could be followed:

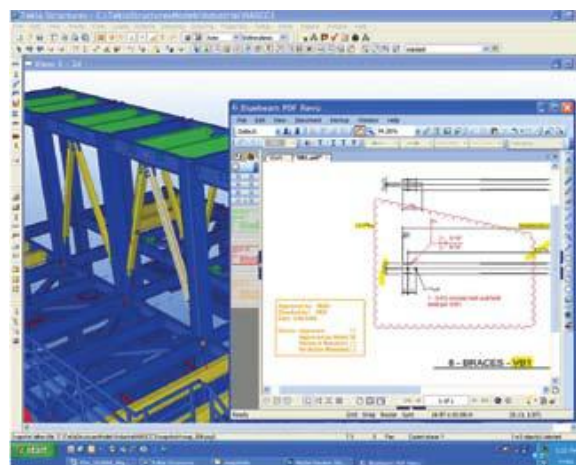
- Generate the views from BIM model,
- Add details using 2D lines and touch up the line works,
- Add location information, dimensions and annotations,
- Place in drawings sheets with Title block and
- Save or print to issue the drawings.



*Figure 18 Architectural roof details using a hybrid approach in which the joint details were added in the view using 2D lines*

There are three possible ways to review and approve shop drawings:

- **2D Review:** This is the traditional method where review and approval are based on 2D shop drawings. The use of the BIM model is limited here.
- **2D + 3D Review:** The reviewing process has incorporated visual check on BIM model besides the normal 2D shop drawings review. The approval process is still based on the 2D shop drawings



*Figure 19 Approved assembly shown in both the 3D model and on the 2D electronic drawings in PDF format (Courtesy of Tekla)*

- **3D Review:** The actual review and approval are done on the construction or fabrication model. This process is recommended when design is very complex so much so that generating the shop drawing becomes very cluster and confusing to interpret that makes the entire review process highly ineffective.

The screenshot shows the 'Tekla Structures Beam (1)' dialog box with the following sections:

- Released:** Includes checkboxes for 'Released' (checked), 'Glolman Simpson' (checked), 'Issue No' (checked), and 'Date' (checked).
- Left Conn / Right Conn / Comments:** Each has a checked checkbox and a field for 'Initial', 'Carron', and 'Date'.
- For-Approval:** Includes checkboxes for 'For-Approval' (checked), 'Dowco Released' (checked), 'Trans#' (checked), 'Rev#' (checked), and 'Date' (checked).
- Reviewer / Left Conn / Right Conn / Comments1 / Comments2 / Add'l Docs:** Each has a checked checkbox and a field for 'Initial', 'Engineer' (with a dropdown set to 'Choose ONE'), and 'Date'.
- Reviewed / Comments:** Includes checkboxes for 'Reviewed' (checked) and 'Comments' (checked), with a field for 'Initial', 'Architect' (with a dropdown set to 'No'), and 'Date'.

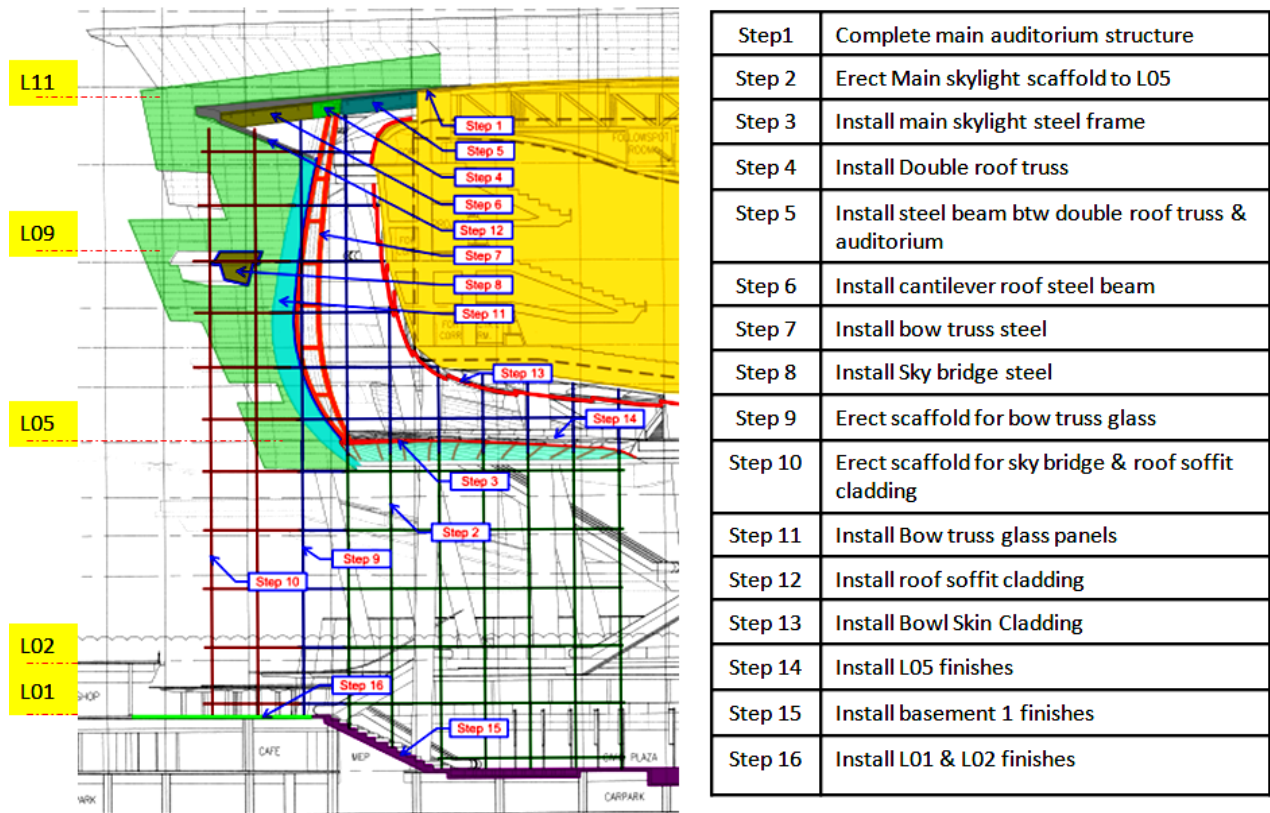
At the bottom, there are buttons for 'OK', 'Apply', 'Modify', 'Get', a checked checkbox, and 'Cancel'. A disclaimer text is also present: 'Reviewed only as to general conformity with the design concept. The Engineer does not warrant or represent that the information on this drawing is either accurate details and dimensions shall remain with Carron'.

Figure 20 Electronic shop drawing approval (Courtesy of Tekla)

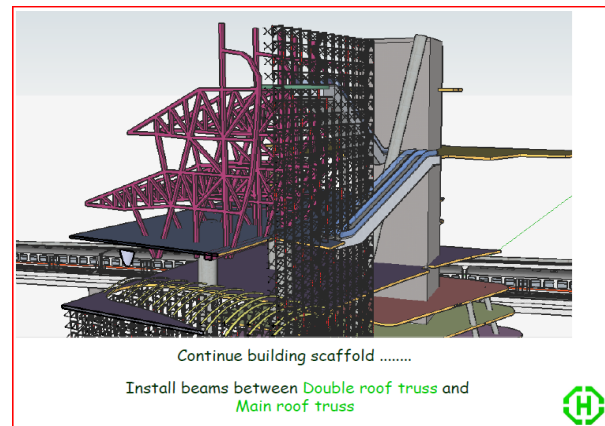
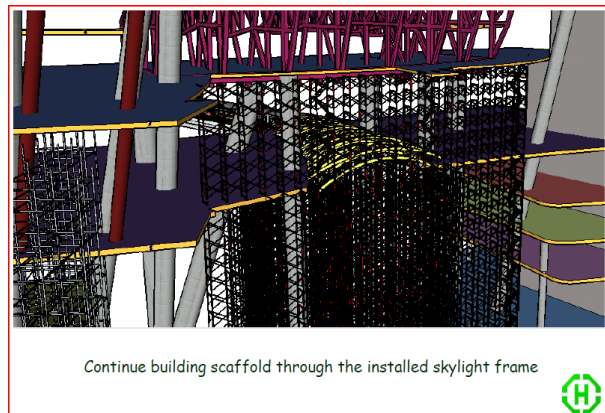
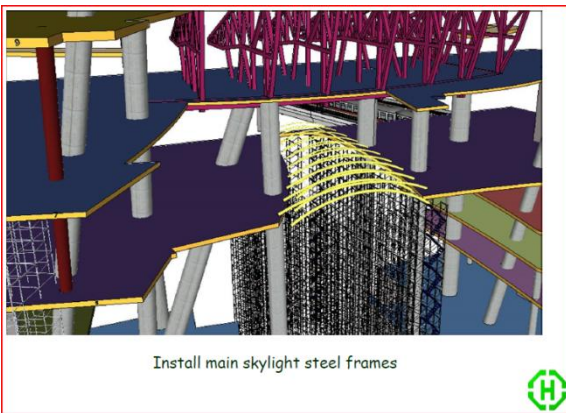
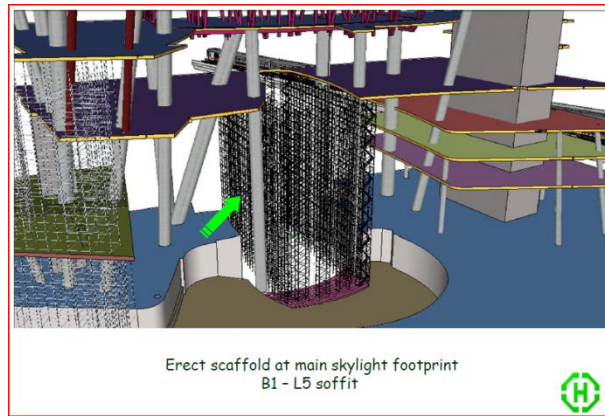
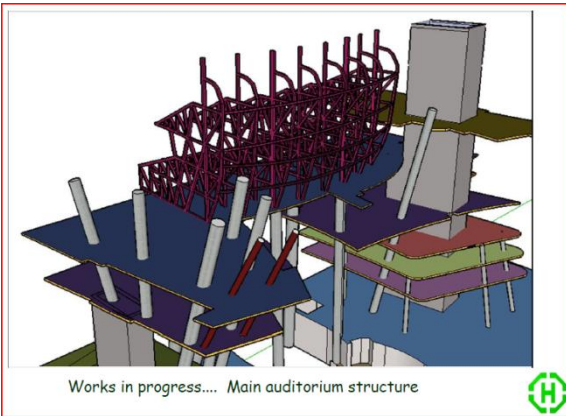
## SEQUENCING COMPLEX CONSTRUCTION

Here, contractor could plan construction operation sequence. Construction planners could perform the following:

- Identifying clashes (e.g. in schedule) and interference problem,
- Map out the construction schedule,
- Communicating complex sequence to site staff



*Figure 21 To avoid any construction issue, a 3D sequencing study was conducted to achieve the optimum installation sequence (Image courtesy of Hexacon Construction Pte. Ltd.)*



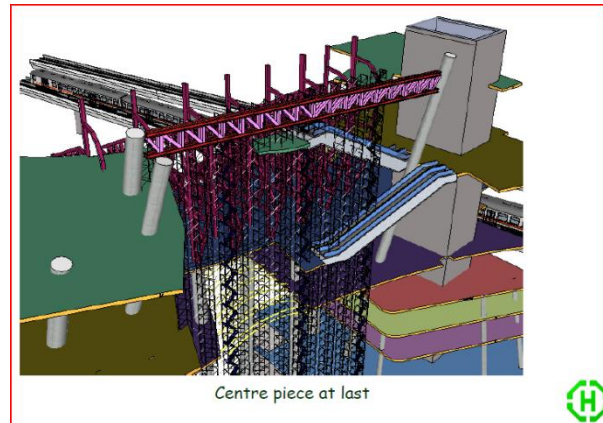
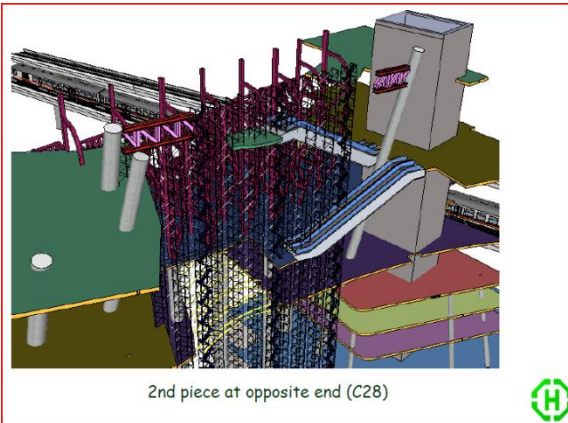
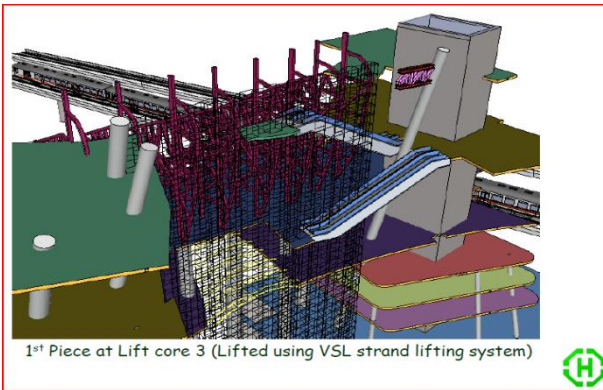
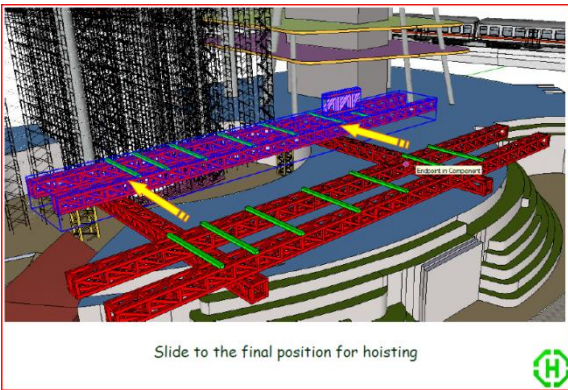
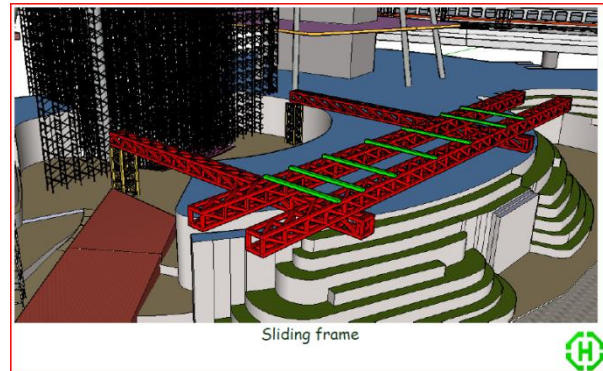
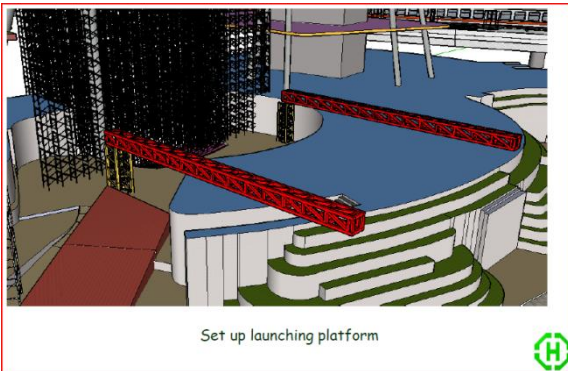
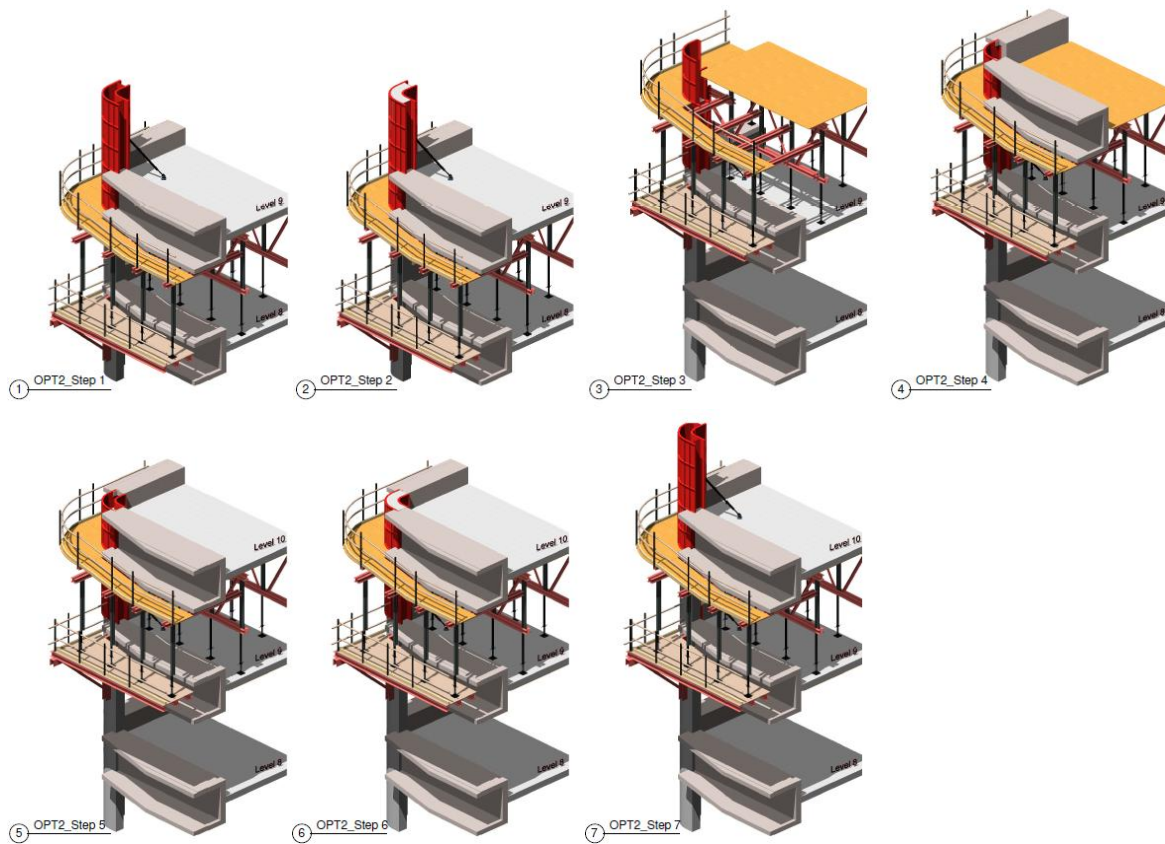


Figure 22 Construction Sequence at East Elevation of Civic, Cultural, and Retail Complex - CCRC (Image courtesy of Hexacon Construction Pte. Ltd.)



*Figure 23 3D Sequencing was used to show the sub-contractors on the sequence how the building elements should be constructed (Image courtesy of Woh Hup Pte. Ltd.)*

## SETTING OUT AND VERIFICATION ON SITE

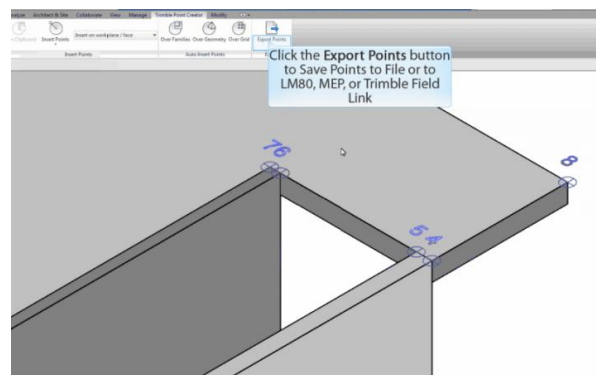
The BIM model could also be used on the construction site to improve the productivity and accuracy when setting out. To use the BIM model on site, several equipments are needed such as Robotic Total Station. Refer to [www.bimtofield.com](http://www.bimtofield.com) website to find more information on extending BIM data to the field.



*Figure 24 Field survey set-out tools example*

The following steps are involved<sup>5</sup>:

- Request set-out information for specific area from consultant
- Review 2D drawings
- Request for the BIM model if the 2D drawings are approved
- Identify set-out points in the BIM model
- Export points to field survey set-out tool
- Set-out on site and generate log report
- Issue any deviations to consultant



*Figure 25 Exporting points to field survey set-out tool*

<sup>5</sup> <http://bimfix.blogspot.sg/2013/04/using-bim-directly-for-component-set-out.html>



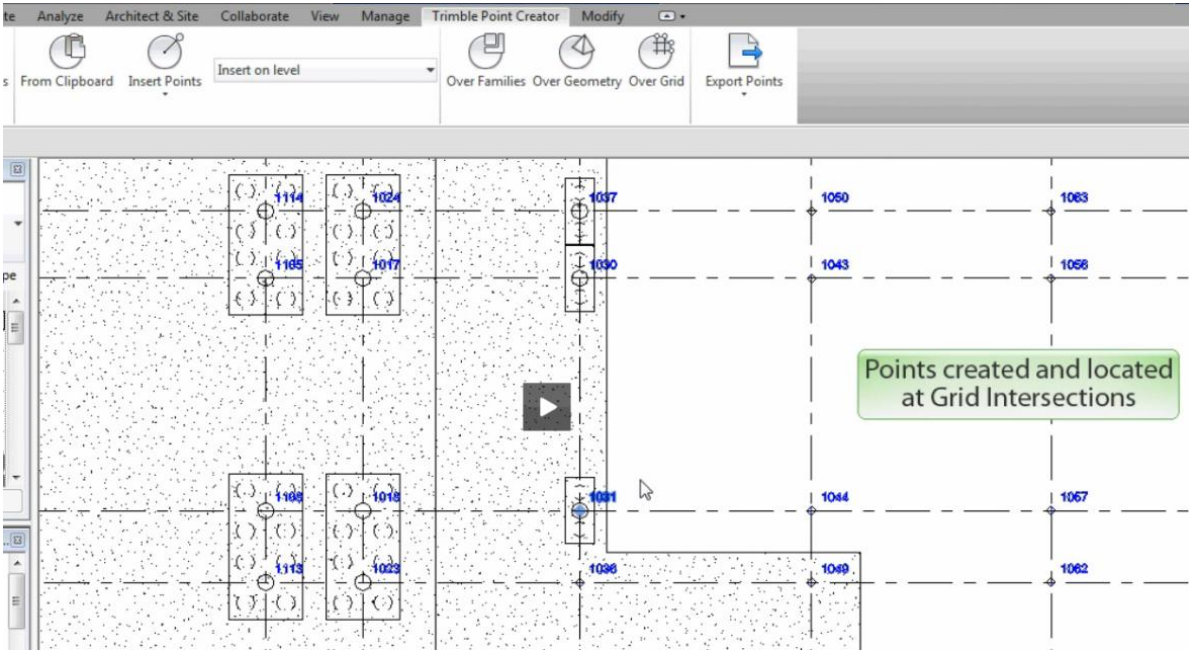


Figure 26 Verification of site points to model

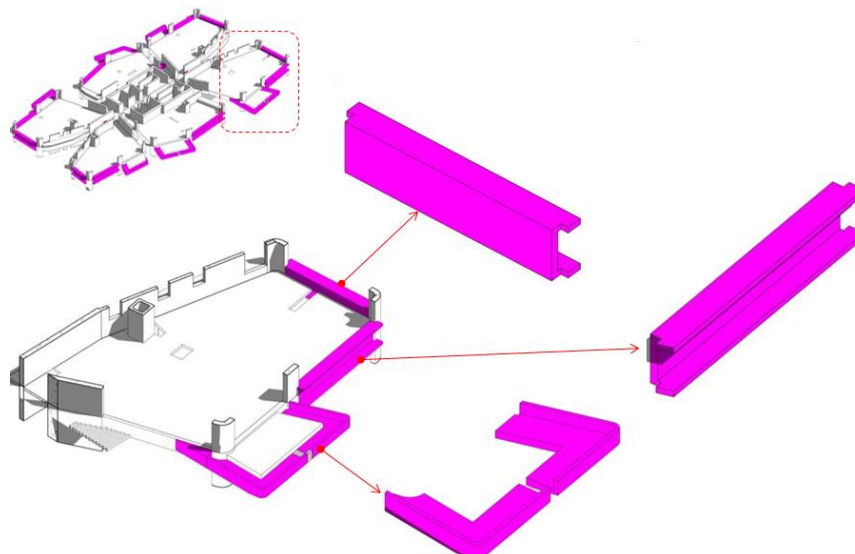
## PREFABRICATION

With fully coordinated model, contractor could analyse and isolate which elements/assemblies to be prefabricated. The first thing to check is whether there are any non-standard elements which can be standardised. The next step would be to identify any similar or identical and repetitive elements which can be prefabricated.

Door Schedule				
Family	Door Type	Height	Width	Count
1st Storey Level				
Dbf Glass (3)		2375	1975	1
1				
M_Double-Flush		2100	1600	1
M_Double-Flush		2100	1800	2
M_Double-Flush		2100	1852	5
M_Double-Flush	FD	2324	1200	6
M_Double-Flush		2324	1900	12
M_Double-Flush	FD	2324	1950	4
30				

*Figure 27 Schedule could be used to identify repetitive element and non-standard elements*

Some example of elements that can be prefabricated are walls, slabs, columns, beams, stairs, doors, windows, curtain walls, claddings, ceilings, parapets, railings, speciality equipments, transport elements, toilets, insulated ducts, and MEP assemblies.



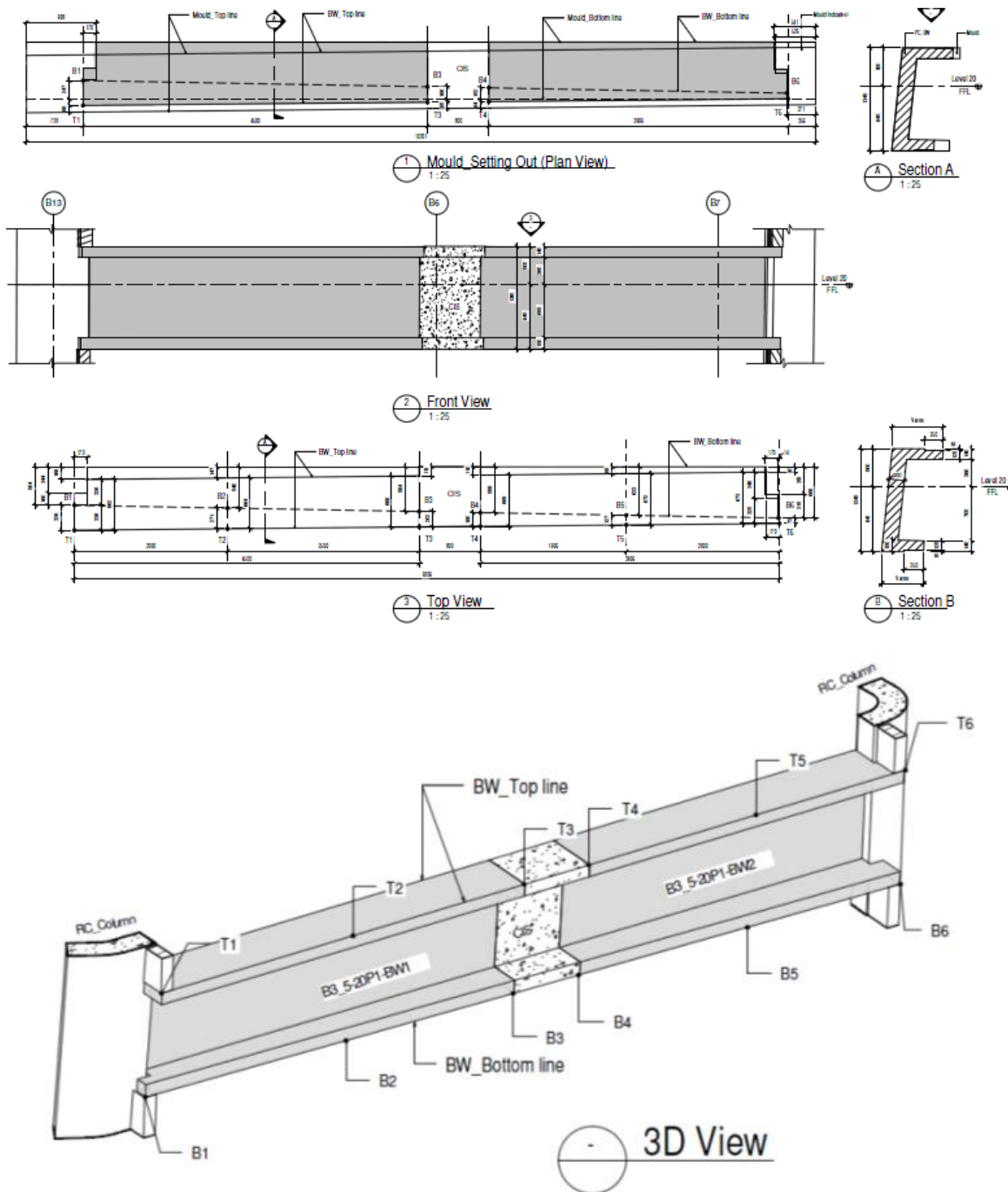
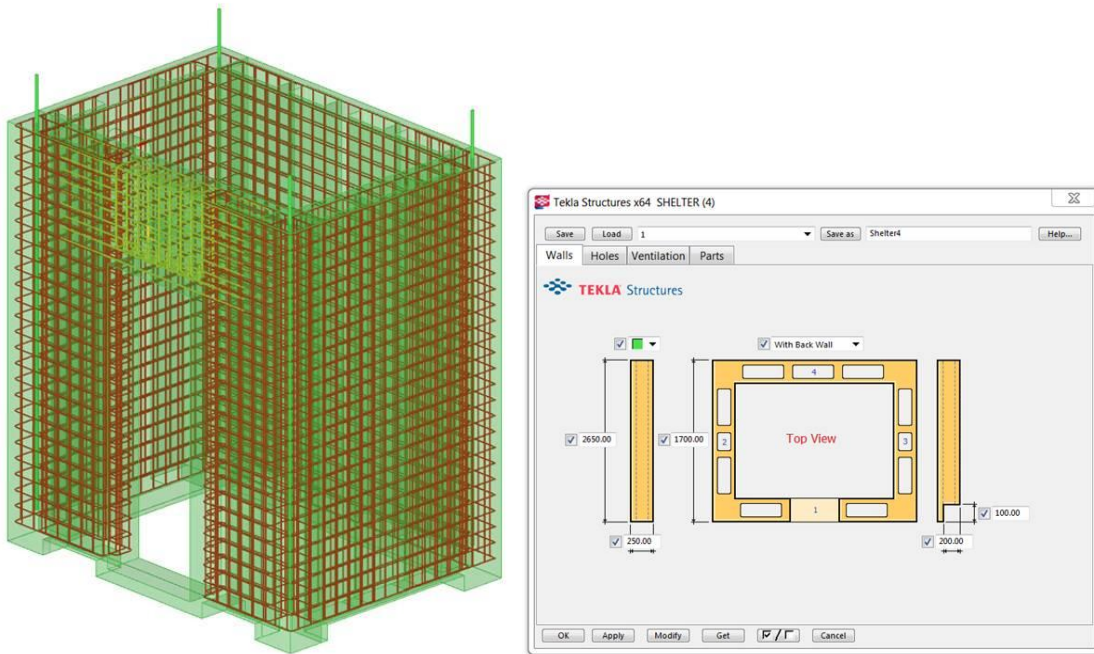
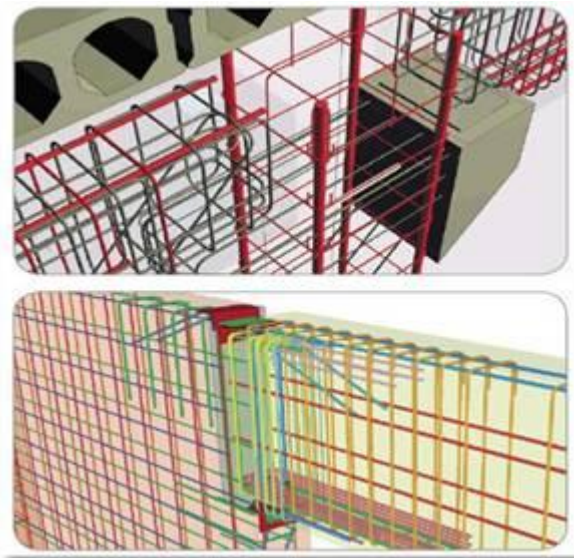


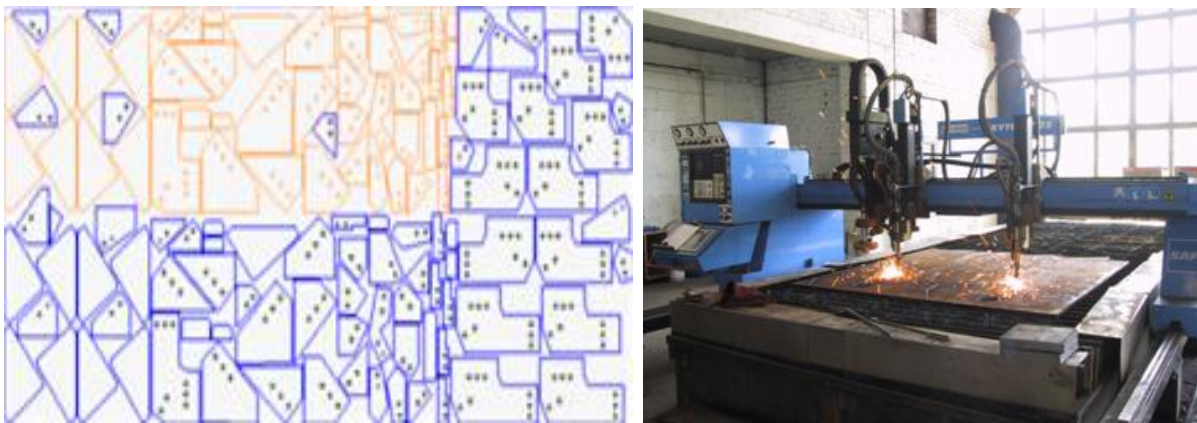
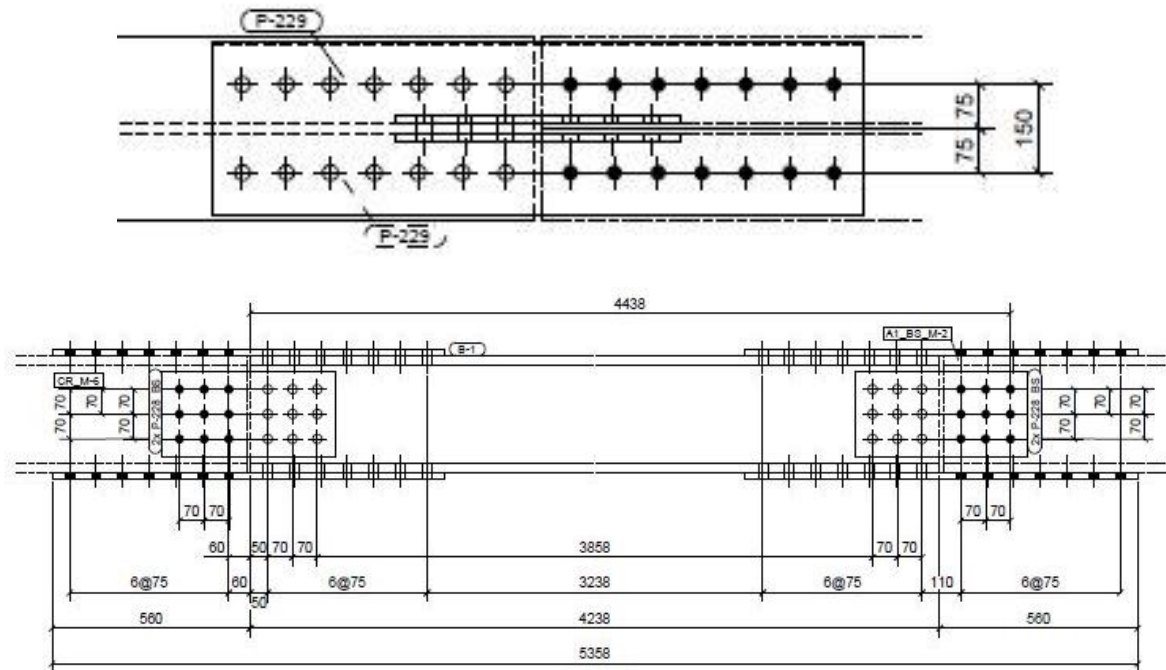
Figure 28 Prefab elements (Image courtesy of Woh Hup Pte. Ltd.)



*Figure 29 A typical parametric precast library for house-hold shelter (Image Courtesy of Tekla)*



*Figure 30 Reinforcements are modelled in working environment which will enable rebar clash detection, bar bending schedule report and fabrication drawings (Image courtesy of Tekla)*



*Figure 31 Data from the BIM model could be exported to CNC machine file format for steel cutting*

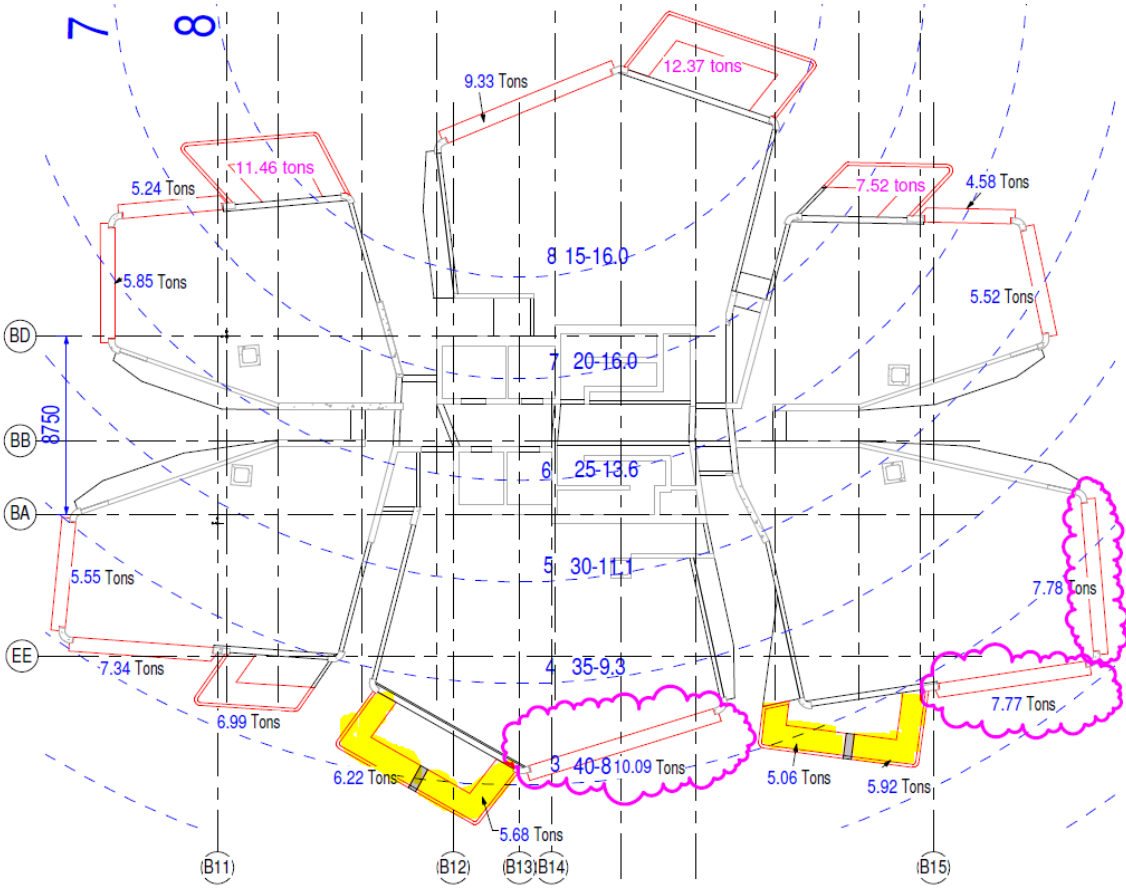


Figure 32 Contractor could decide the weight of the precast/prefab component based on the crane location and capacity as shown in the picture (Image courtesy of Woh Hup Pte. Ltd.)

## PREPARATION OF AS-BUILT MODEL

In preparing as-built model, contractor could use the consultants' model and update the model based on the design changes throughout the construction stage. Once the contractor finishes with the final as-built models, the consultants can either confirm using the as-built models or drawings produced by the contractors are in accordance to the final approved amendment plans submitted to the relevant authorities.

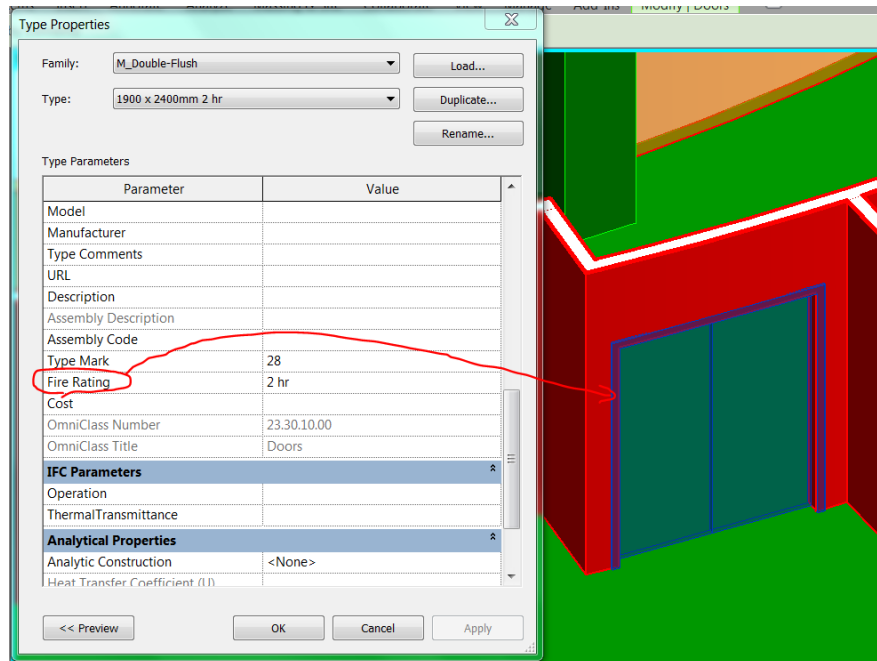
As a good practice, contractor should not overly model the as-built model which could be supplemented with the shop drawings and installation details.



*Figure 33 Updating As-Built model as per design changes (Image courtesy of Lian Soon Construction Pte. Ltd.)*

## PREPARATION OF BIM MODEL FOR OPERATION AND MAINTENANCE

In preparing the BIM model for Operation and Maintenance, contractor should add O&M information to the as-built model based on the requirements from the client or O&M team.



*Figure 34 The O&M team could request the contractor to fill in the value of Fire Rating door into the door element*

The table below shows an example of the information required by the O&M team.

	O&M INFORMATION REQUIREMENTS	INFORMATION FROM THE EQUIVALENT BIM ELEMENT
<b>Fire extinguishers</b>	<ul style="list-style-type: none"> <li>• Location</li> <li>• Type</li> <li>• Supplier</li> <li>• Expiry Date</li> </ul>	Representation as an object and location Attributes to be provided as part of the info: <ul style="list-style-type: none"> <li>• Type - Model make</li> <li>• Supplier - Name</li> <li>• Expiry Date – Date</li> </ul>
<b>Breakout glass</b>	<ul style="list-style-type: none"> <li>• Location</li> </ul>	Object representation and location



	O&M INFORMATION REQUIREMENTS	INFORMATION FROM THE EQUIVALENT BIM ELEMENT
<b>Fire sprinklers</b>	<ul style="list-style-type: none"> <li>• Location</li> <li>• Type</li> <li>• Supplier</li> </ul>	Representation as an object and location Attributes to be provided as part of the info: <ul style="list-style-type: none"> <li>• Type - Model make</li> <li>• Supplier - Name</li> </ul>
<b>Fire valves etc</b>	<ul style="list-style-type: none"> <li>• Location</li> <li>• Type</li> <li>• Supplier</li> </ul>	Representation as an object and location Attributes to be provided as part of the info: <ul style="list-style-type: none"> <li>• Type - Model make</li> <li>• Supplier - Name</li> </ul>
<b>Fire pumps</b>	<ul style="list-style-type: none"> <li>• Location</li> <li>• Type</li> <li>• Supplier</li> <li>• Pump</li> </ul>	Representation as an object and location Attributes to be provided as part of the info: <ul style="list-style-type: none"> <li>• Type - Model make</li> <li>• Supplier - Name</li> <li>• Pump Capacity</li> </ul>
<b>Chillers</b>	<ul style="list-style-type: none"> <li>• Location</li> <li>• Type</li> <li>• Supplier</li> <li>• Pump Capacity</li> </ul>	Representation as an object and location Attributes to be provided as part of the info: <ul style="list-style-type: none"> <li>• Type - Model make</li> <li>• Supplier - Name</li> <li>• Pump Capacity</li> </ul>
<b>Lights</b>	<ul style="list-style-type: none"> <li>• Location</li> <li>• Type</li> <li>• Supplier</li> <li>• Expiry Date</li> </ul>	Representation as an object and location Attributes to be provided as part of the info: <ul style="list-style-type: none"> <li>• Type - Model make</li> <li>• Supplier - Name</li> <li>• Expiry Date - Date</li> </ul>
<b>Motion sensors</b>	<ul style="list-style-type: none"> <li>• Location</li> <li>• Type</li> <li>• Supplier</li> </ul>	Representation as an object and location Attributes to be provided as part of the info: <ul style="list-style-type: none"> <li>• Type - Model make</li> <li>• Supplier - Name</li> </ul>
<b>Control meters</b>	<ul style="list-style-type: none"> <li>• Location</li> <li>• Type</li> <li>• Supplier</li> </ul>	Representation as an object and location Attributes to be provided as part of the info: <ul style="list-style-type: none"> <li>• Type - Model make</li> <li>• Supplier - Name</li> </ul>

## Appendix A – Suggested Colour Coding for Modelling

### ACMV

SYSTEM TYPE	COLOR	RED	GREEN	BLUE
Supply Air	150	0	127	255
Return Air	92	0	189	0
Fresh Air	200	191	0	255
Exhaust Air	34	129	64	0
Primary Air	130	0	255	255
Kitchen Supply Air	210	255	0	255
Stair Pressurization Air	200	191	0	255
Lobby Pressurization Air	200	191	0	255
Toilet Exhaust Air	34	129	64	0
Kitchen Exhaust Air	40	255	191	0
Smoke Engineering Air	34	129	64	0
Chilled Water Supply Pipe	55	129	129	86
Chilled Water Return Pipe	55	129	129	86
Refrigerant Pipe	55	129	129	86
Condensate Drain Pipe	55	129	129	86
Mechanical Equipment	32	189	94	0
Motor Control Panel	32	189	94	0
Supply Air Grille	151	170	212	255
Return Air Grille	93	126	189	126
Fresh Air Grille	201	234	170	255
Exhaust Air Grille	35	129	107	89
Primary Air Grille	131	170	255	255
Kitchen Supply Air Grille	211	255	170	255
Toilet Exhaust Air Grille	35	129	107	89
Kitchen Exhaust Air Grille	41	255	234	170
Fire Damper	244	129	0	31
Motorized fire Damper	7	255	255	255
Damper	7	255	255	255
Access Panel	7	255	255	255
ACMV Text	52	189	189	0
Equipment Text	32	189	94	0

**ELECTRICAL**

SYSTEM TYPE	COLOR	RED	GREEN	BLUE
Normal Power Cable Tray/Trunking/Ladder (Hatch)	131	170	255	255
Emergency Power/GSM/Security Cable Tray/Trunking/Ladder (Hatch)	80	63	255	0
Telecommunication System (Tel/Data Scv)	131	170	255	255
Power System	80	63	255	0
Public System	80	63	255	0
Lighting Fixture	241	255	170	199
Lighting Fixture	71	212	255	170
Lighting Circuit (Dashed Line Type)	51	255	255	170
Lighting Circuit (Divide Line Type)	61	234	255	170
Lighting Fixture	131	170	255	255
Lighting Fixture	71	212	255	170
Electrical Equipment	2	255	255	0
Electrical Panel	80	63	255	0
Electrical Power Bus-Bar Trunking	2	255	255	0
Electrical Equipment (Centre Line Type)	2	255	255	0
Cable TV Lead-In Pipes/ Underground Cables	230	255	0	127
Security System/ Electrical Opening	141	170	234	255
Telephone Lead-In Pipes	230	255	0	127
TV Antenna System, Cable TV System (TV Pt., Data Pt., Tele Pt. Etc...)	131	170	255	255
Revision Cloud	50	255	255	0
Electrical Lead-In Pipe/ Underground Cables (Hidden Line Type)	2	255	255	0

**PROTECTION, PLUMBING, SANITARY & GAS**

<b>SYSTEM TYPE</b>	<b>COLOR</b>	<b>RED</b>	<b>GREEN</b>	<b>BLUE</b>
Fire Protection Pipe	241	255	170	191
Fire Protection Concealed Pipe	134	0	129	129
Fire Protection Exposed Pipe	231	255	170	212
Sanitary SWP	240	255	0	63
Sanitary WP	240	255	0	63
Vent	94	0	129	0
Domestic Cold Water Booster Pipe	214	129	0	129
Domestic Cold Water Gravity Pipe	240	255	0	63
Domestic Cold Water Transfer Pipe	230	255	0	127
Domestic Hot Water Booster Pipe	214	129	0	129
Domestic Hot Water Gravity Pipe	240	255	0	63
Domestic Hot Water Return Pipe	30	255	127	0
NEWater Water Booster Pipe	214	129	0	129
NEWater Water Gravity Pipe	240	255	0	63
NEWater Water Transfer Pipe	230	255	0	127
Plumbing Annotation	51	255	255	170

*This guide is part of the BIM Essential Guide Series*

BIM Essential Guide	FOR EACH BIM PROJECT		FOR EACH ORGANIZATION
	WITHIN EACH DISCIPLINE	ACROSS MULTIPLE DISCIPLINES	ALL DISCIPLINES
For Architectural Consultants	●		
For C&S Consultants	●		
For MEP Consultants	●		
For Contractor	●		
For BIM Execution Plan		●	
For BIM Adoption in an Organization			●



Building and Construction Authority  
5 Maxwell Road  
#16-00 Tower Block MND Complex  
Singapore 059110  
[www.bca.gov.sg](http://www.bca.gov.sg)

For more information and feedback on the BIM Essential Guide Series, please visit the following blog:

[bimsg.wordpress.com](http://bimsg.wordpress.com)

